

6817 Greenwood

6817 Greenwood Ave N // Project# 3032679-EG
Early Design Guidance Application // Northwest Design Review Board
Meeting Date // 03 May, 2021

6817 Greenwood Partners, LLC

workshop AD
ROOT OF DESIGN

table of contents

development objectives	3
community outreach summary	3
living building pilot program	4
site information	6
urban analysis	8
neighborhood use and zoning	14
design guidelines	16
architectural concepts	18
landscape concept	36
departures	38
architect developer housing projects	44
appendix	45

Copyright 2021
Workshop AD

No part of this document may be reproduced, distributed or transmitted in any form or by any means, including photocopying, recording, or other electronic or mechanical methods, without the prior written permission of Workshop AD.

proposal

Address:	6817 Greenwood Ave N Seattle WA 98103
SDCI Project Number	3032679-EG
Developer Applicant	6817 Greenwood Partners Workshop AD

The project site is a mid-block lot just south of the intersection of Greenwood Ave North and North 70th Street. Greenwood Ave North is a minor arterial with frequent transit service that extends from Phinney Ridge to northern neighborhoods. Existing structures range from single family homes on small parcels to half block mixed-use developments. The development pattern is varied and in transition with a vibrant mix of cultural, residential, local service businesses, restaurants, and shops.

The lot is zoned NC2-55(M) with a zone transition at the west property line to single-family zone. To the north is Woodland Park Presbyterian Church; to the south is the four story Fini Condominium, and to the west is a two story childcare center.

The proposed project is six story apartment building with 24 dwelling units and seeks to qualify for the Living Building Pilot Program. As the lot is mid-block with no alley access, the first story includes or provides access to the residential entry, amenity areas, bicycle parking, waste and recycling storage, and ground level dwelling units. An outdoor amenity area, vegetated roof, and solar is proposed for the roof.

The design proposal responds to five primary considerations:

- 1. Maintain and enhance the well-established urban edge along Greenwood/Phinney Ridge corridor**
- 2. Respond to the scale of the adjacent structures through setback and facade modulation**
- 3. Create a sustainable focused multifamily community**
- 4. Provide varied dwelling unit options**
- 5. Engage with the distant views**

public outreach summary



The primary phase of Community Outreach occurred between October 17th, 2020, and February 2nd, 2021. During this time, fliers and posters were published to inform the community of this proposal. Questions and comments were recorded via Phinney Ridge Community meetings, emails, and the interactive blog on the project website. The project team has also met with the owners association of the Fini Condominiums and had three meetings with the Woodland Park Presbyterian Church to discuss design alternatives. Through these methods, the design team described preliminary design considerations and solicited feedback on design issues, community priorities, and key aspects of the neighborhood the design team should be aware of.

Community members expressed:

- Hope for an architectural style that is compatible with the existing neighborhood, especially in terms of façade material. (brick, or similar finish, is mentioned to be favorable)
- Encourage diversity in unit type/size
- Bikes should be stored in the building, not at front of building along the sidewalk
- Staging of solid waste carts at collection day should be avoided.
- Design balconies at the west in a way that respect the privacy of condo balconies.
- Support setback at ground level to provide wider sidewalk and public realm.
- Bikes should be stored in the building, not at front of building along the sidewalk.
- Walkable neighborhood, green spaces along sidewalk
- Hope for the street trees to be replaced.
- Sun and shade
- Concern about the scale of the building especially with the bonus height of LBC

living building pilot program

The Living Building Pilot Program provides height and floor area incentives for buildings in exchange for meeting high-performance green building requirements and allows an applicant to request additional departures from the Seattle Land Use Code through Design Review.

City of Seattle Minimum Standards

A project shall qualify for the Living Building Pilot Program if it:

1. Achieves Living Building Challenge v4.0 full certification
2. Achieves Petal Certification under the Living Building Challenge v4.0 and:
 - Reduces total energy use by 25% or more based on the Energy Use Intensity (EUI) targets in the Target Performance Path of the Seattle Energy Code Section C401.3 and uses no fossil fuel for space and water heating.
 - Reduces potable water demand by using only non-potable water to meet demand for toilet and urinal flushing, irrigation, hose bib, cooling tower (make up water only), and water features, except to the extent other applicable local, state, or federal laws require the use of potable water.

Petal Certification Requirements

For Living Building Challenge (LBC) V4.0 petal certification, all core imperatives are required, plus the remaining imperatives to complete either the Water, or Energy or Materials Petal.

incentives:

- Up to 25 percent more floor area
- 12.5 feet of additional height for residential construction or 15 feet of additional height for non-residential construction in zones with height limits of 85 feet or less
- Additional design departures for the pilot programs as specified in SMC 23.41.012D

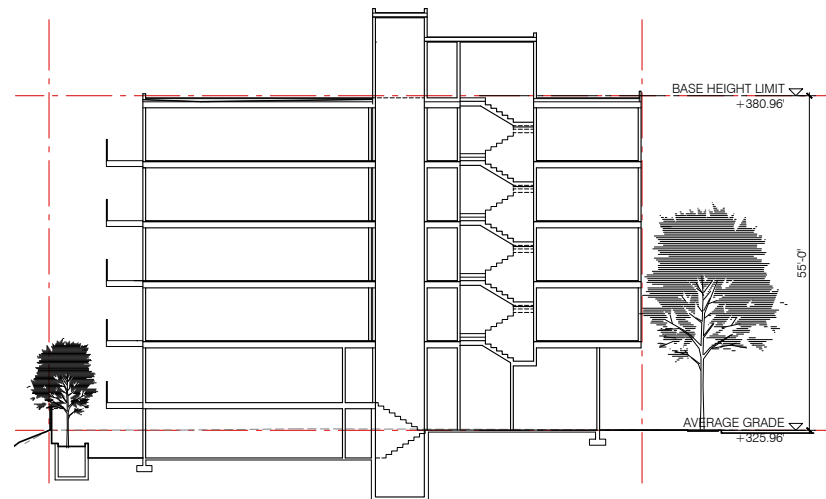

section // base zoning

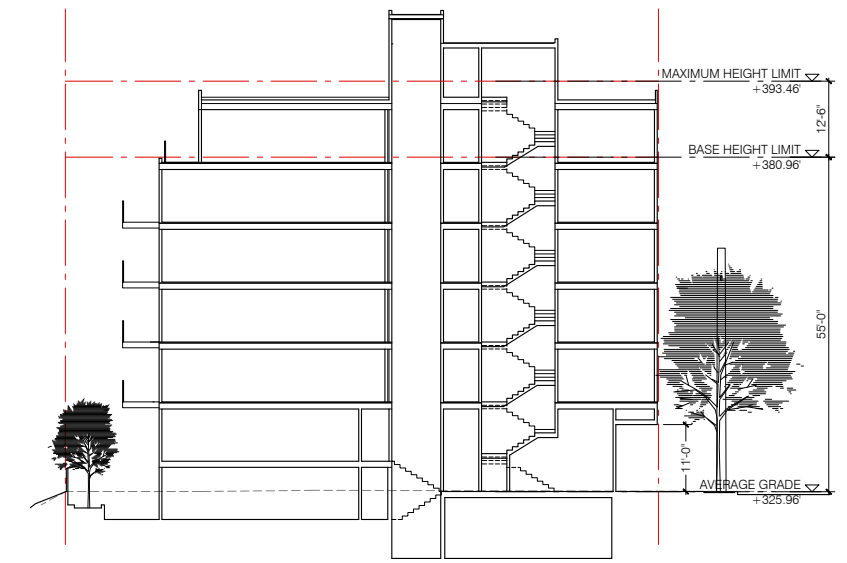

section // LBC incentive

required imperatives

This project is planning on pursuing compliance with LBC v4.0 Petal Certification by pursuing the Energy, Equity, and Beauty Petals.

Energy

I-07 Energy + Carbon Reduction
I-08 Net Positive Carbon

Equity

I-17 Universal Access
I-18 Inclusion

Beauty

I-19 Beauty + Biophilia
I-20 Education + Inspiration

Additional required imperatives (core imperatives):

Place

I-01 Ecology of Place
I-04 Human-scaled Living

Water

I-05 Responsible Water Use

Health + Happiness

I-09 Healthy Interior Environment

Materials

I-12 Responsible Materials

proposed petal certification

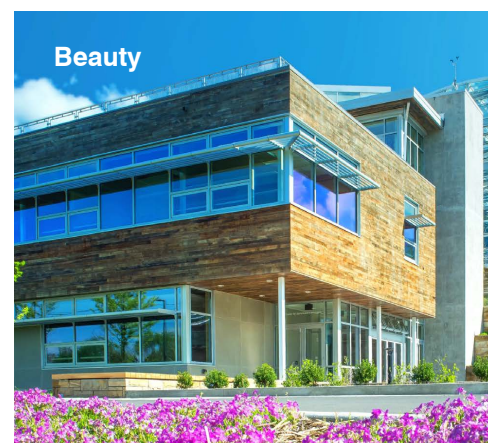
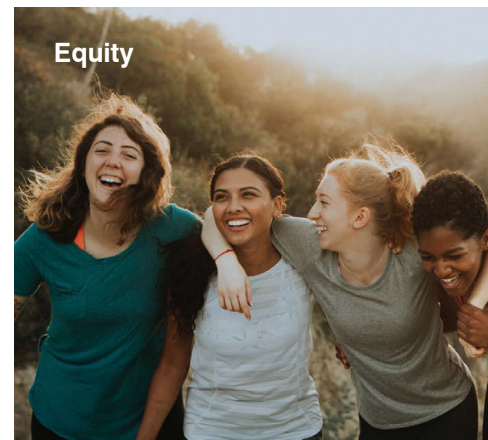

petal intent

Energy

The intent of the Energy Petal is to treat energy as a precious resource by minimizing energy-related carbon emissions and embodied carbon, both of which contribute to climate change. The Petal requires that projects supply 105% of their energy needs through renewable energy, without the use of combustion and account for the total embodied carbon emissions from construction through carbon-sequestering materials or a one-time carbon offset purchase.

Equity

The intent of the Equity Petal is to elevate equity as a project goal, and to transform developments to foster a just and inclusive community that enables all people to participate, prosper, and reach their full potential. Living Buildings are meant to be accessible and welcoming to all people, helping us recognize and celebrate cultural richness, while ensuring equitable access to fresh air, sunlight, and clean water and soil.

Beauty

The intent of the Beauty Petal is to recognize the need for beauty and the connection to nature as a precursor to caring enough to preserve, conserve, and serve the greater good. The key to creating beautiful buildings is to embrace a biophilic design process that emphasizes that people and nature are connected and the connection to place, climate, culture and community is crucial to creating a beautiful building.

aspirations



Zero Cottage | Place + Energy



ETSY Headquarter | BrooklynNY



Bullitt Center | Seattle WA

project approach

Lower embodied carbon materials will be prioritized for the primary building materials and the project will account for the total embodied carbon emissions from construction through the utilization of carbon-sequestering materials and/or a one-time carbon offset purchase. Additionally, the building will incorporate a resilience strategy to ensure the building can remain habitable to its residents in the case of an emergency.

The project will provide and enhance the public realm through design measures and safeguard access for those with physical disabilities. The project will mitigate negative impact to adjacent properties through setback and building system.

The project will include project team organizations with Just label and MWDBE certification throughout the design and construction phases.

The project will meaningfully integrate public art and contain design features intended solely for human delight and celebration of culture, spirit, and place of the Greenwood neighborhood.

The project will provide educational materials about the building, including an LBC case study, copy of the operations and maintenance manual, and an educational website. The project will also incorporate interpretive educational signage and a brochure describing the design and benefits of the project and will connect visitors and occupants of the building to the energy and water performance. The project will also have an annual open day to the public.

Please see appendix for detailed LBC requirements and project approach.

site information

topographical survey

The site is generally flat with approximately 2 feet of topographic change across the site. There are no exceptional trees on the site. The site sits at the high point of the ridge where there are excellent views to the west and east.

6817 Greenwood Ave N
 APN 2877103940
 Lot Area = 3,413 sf

Legal Description -

lot 21 and the north 10 feet of lot 20, block 22, green lake circle railroad addition to the city of seattle according to the plat thereof, recorded in volume 2 of plats, page 170, in king county, washington;

except the east 10 feet thereof, as conveyed to the city of seattle under condemnation ordinance number 19534;

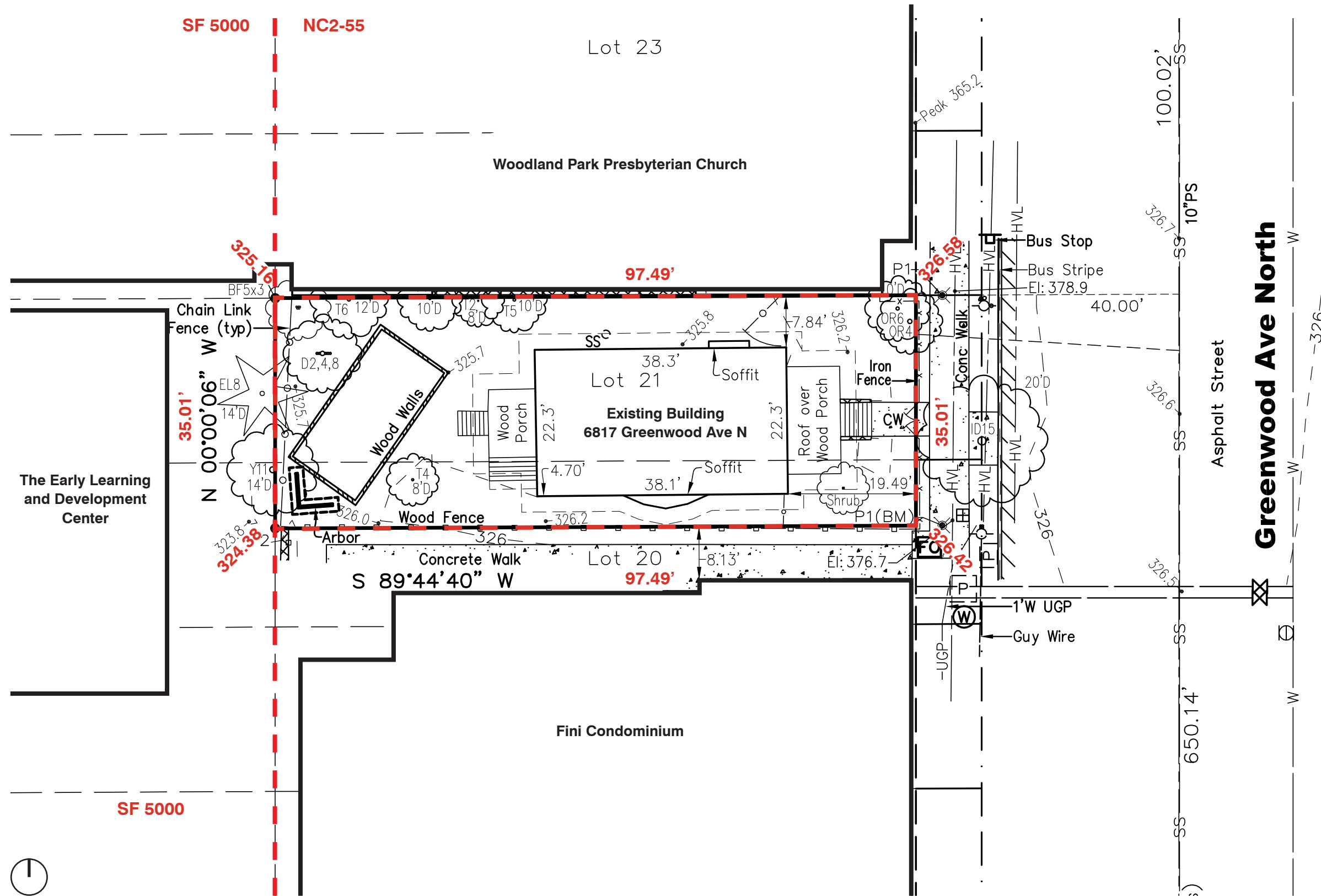

existing site conditions



1. Greenwood Ave West - looking south



2. Greenwood Ave East - looking at the church



3. Greenwood Ave East - looking towards the site

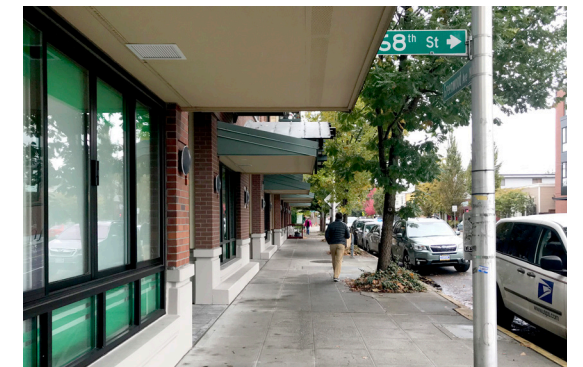

4. Greenwood Ave West - sidewalk condition



5. Greenwood Ave East - looking north



6. Greenwood Ave East - sidewalk condition



7. N 70th St. - looking east



8. Palatine Ave - looking south

urban analysis

neighborhood setting

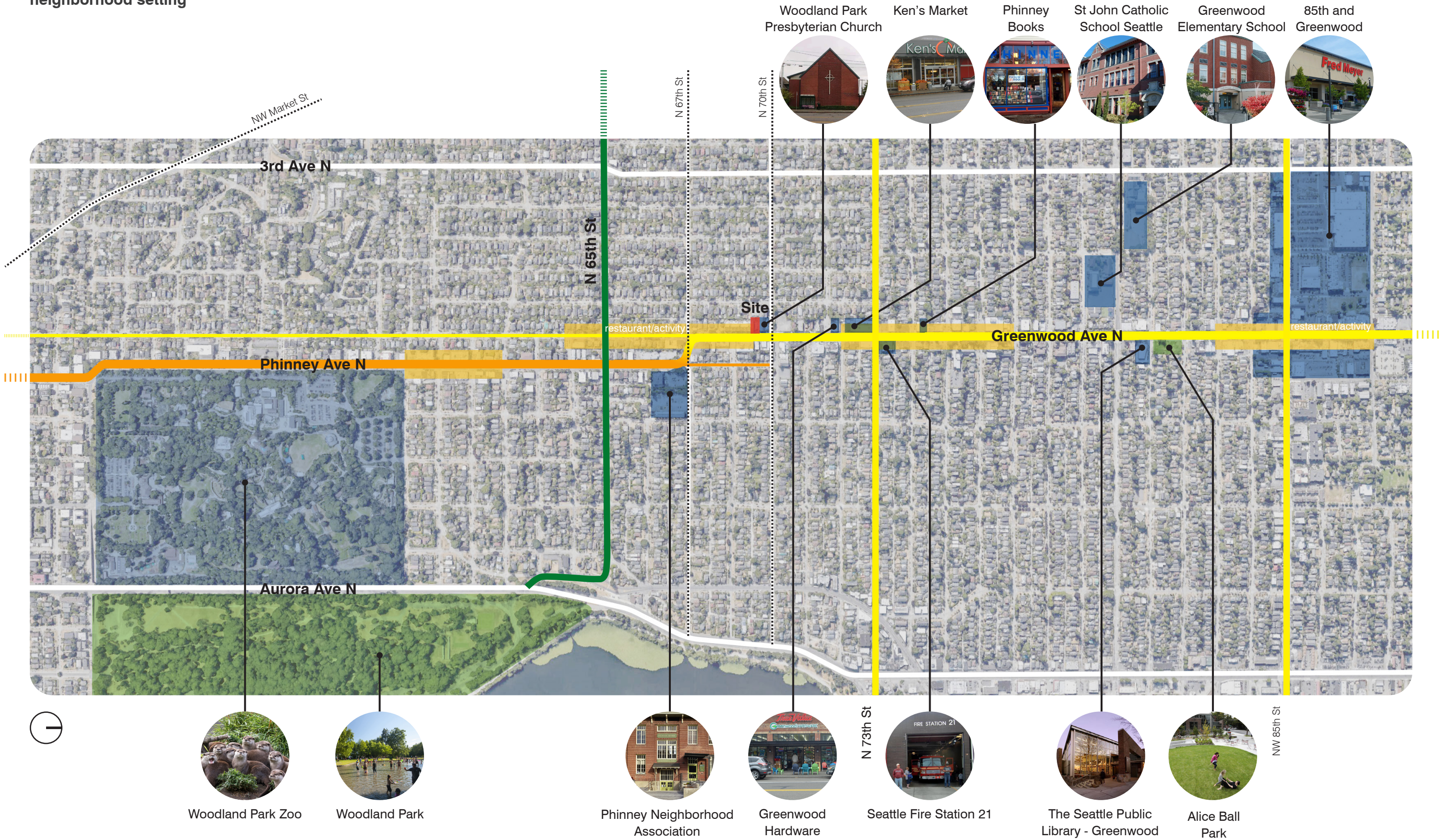

in transition

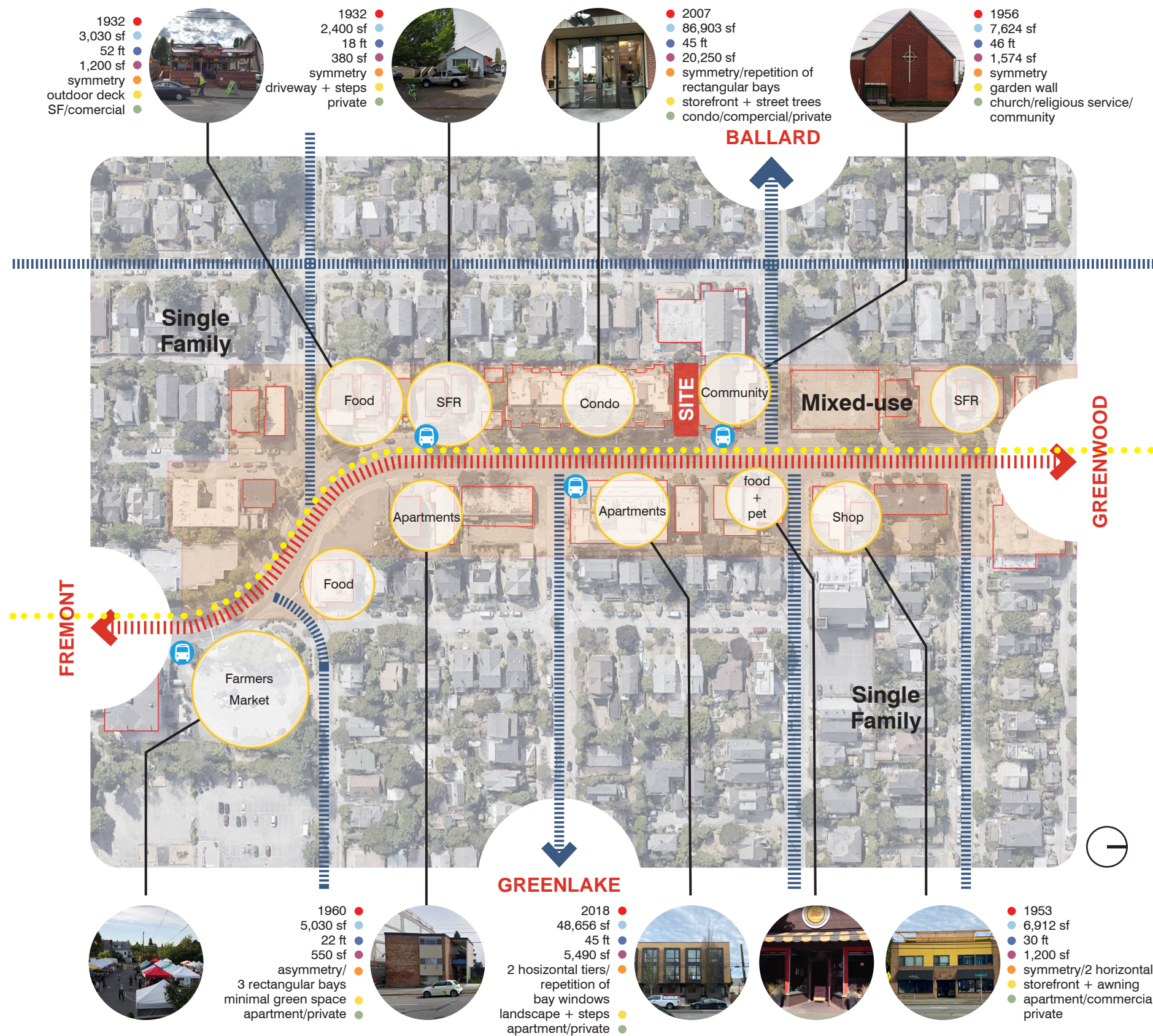

Located on Greenwood Avenue North, the project fronts a lively commercial and residential strip. Served with transit and centered within the well-established single family neighborhood of Phinney Ridge, Greenwood Avenue North is a street in the midst of significant transition. These changes are framed by single family homes from the 1930's at one end and new, half-block, five story mixed use developments at the other. Between is an eclectic mix of mid-century walk-up apartments and one and two story commercial buildings.

With this transition has come a filling in of the street frontage. Small structures that were separated from the sidewalk by surface parking or yards have been replaced by buildings that create a more continuous urban edge. While zoned commercial, recent developments include townhomes and parcel based apartment projects in addition to the larger mixed use projects.

Current development reveals two zoning conditions, four story structures prior to MHA adoption, and five stories after, due to a height increase to 55 feet. At both scales, buildings generally have a clearly articulated ground level that is usually occupied by a commercial use. Upper levels employ modulation, bays, and setbacks to reduced the perceived massing.

These typologies set up a two-tier spatial organization, where the public, ground level, is differentiated from the more private living space above. This is accomplished through different ground level conditions. Some projects recess the lower floor, while others utilize canopies and awnings to emphasize the ground floor datum. Instead of story differentiation, most project present a cohesive residential massing where modulation or bays are used to introduce vertically proportioned secondary elements.

streetscape photos

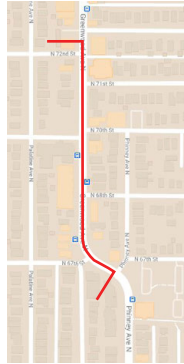

open space
at intersection



side yard parking



planters on
sidewalk



recessed entry
1:3 datum
vertical expression
through modulation



2-story
apartments

2-story
apartments

1-story
Greenfab Custom
Home Builder

1-story
Thaiku
Restaurant

1-story
El Chupacabra
Restaurant

2-story
SFR

1-story
SFR

1-story
Express Dental
Clinic

4-story
Fini Condo

Greenwood Ave N - looking west

outdoor seating



bus shelter
landscape + brick



recessed + canopy
interior court
1+4+1



project site



N 70th St



N 72nd St



project site

Woodland Park
Presbyterian Church

7009 greenwood /
5-story mixed-use
under construction

2-story
SFR

3-story
apartments

1-story
SFR

1-story
SFR

2-story
office building

private
public

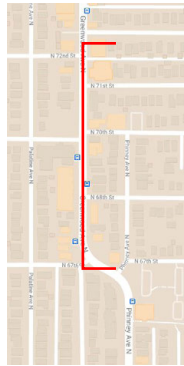

projecting ground level + canopy
modulation and vertical expression
1+3



simple form
+
vertical bay expression
1+2



base
+
modulation
1+4



4-story
Infinity Condo

4-story
apartments

3-story
phinney ridge
townhomes

7006 greenwood
proposed
5-story
apartments

2-story
Adorn

recessed entry



backyard gates and alleyways



limited ground level expression
+ canopy
vertical bay expression
0+4



articulated ground level
+ canopy
vertical + horizontal modulation
1+3+1



tucked-away building entry



elevated building entry



across from site



N 68th St



private
public

2-story
Rub-A-Dub
Dog Wash

1-story
Oliver's Twist
Restaurant

2-story
Johnson & Johnson
Antiques

2-story
office

4-story
Hendon Condos

5-story apartments
Phinney Flats

3-story
apartments

3-story
apartments

zoning data

Zoning	NC2-55(M)
Overlays	Greenwood-Phinney Ridge Residential Urban Village Greenwood / Phinney Neighborhood Design Guidelines
Lot Size	3,413 sf
FAR	3.75 GFA = 12,797 sf
Base Height Limit	55 feet roof top features: +4 feet for parapets, guards, roof decks +16 feet for stair and elevator penthouses and greenhouse
Setbacks	15 feet for portions of structures above 13 feet in height up to 40 feet abutting SF zone. Above 40 feet is 3 feet for every 10 feet of additional height.
Amenity Area	5% of GFA - 640 sf
Parking	none required (frequent transit within urban village)
Solid Waste Storage	375 sf required and 182 sf proposed and preliminarily approved by SPU
Bicycle Parking	24 long term 2 short term required & proposed
Street-level Blank Facades	blank segments between 2 and 8 feet no more than 20 feet total blank facade no more than 40% of the width of the facades
Living Building Incentives	
FAR	additional 25% max GFA = 15,996 sf
Max Ht Limit	67.5 feet

- site
- single family residential
- multi-family housing
- mixed-use
- commercial / retail / office
- civic / religious
- institution / education
- recreation / open space
- proposed housing development
- proposed mixed-use development
- 1/8 mile radius



upper level setback analysis

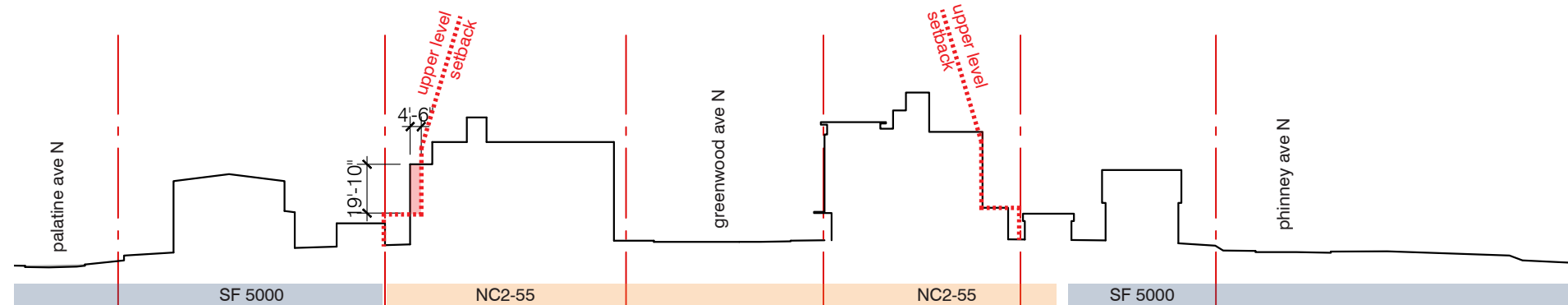
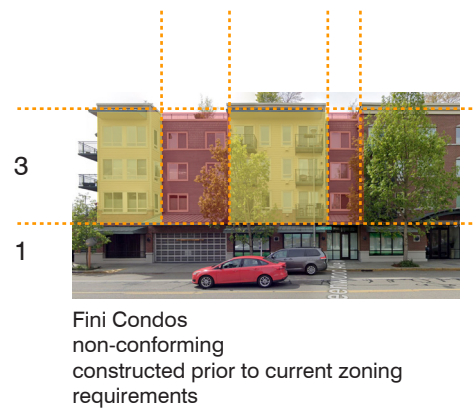
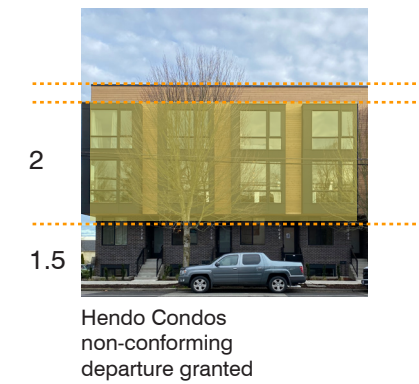
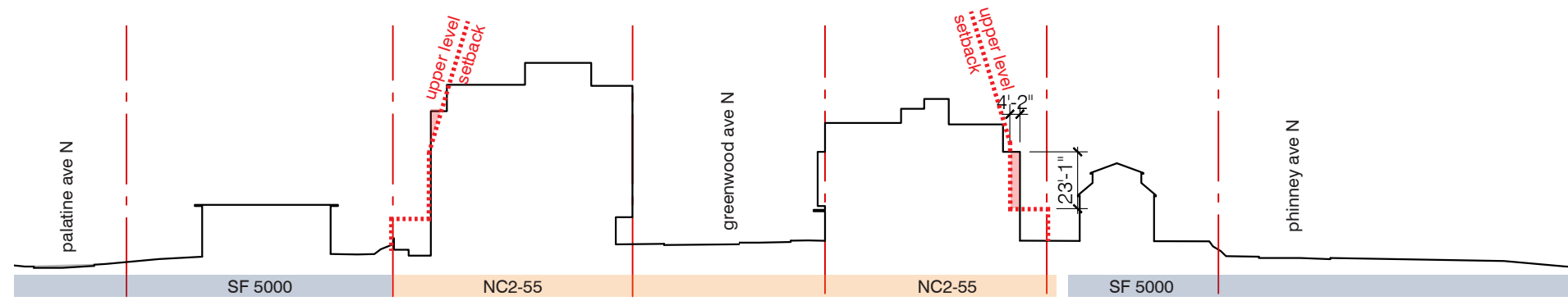
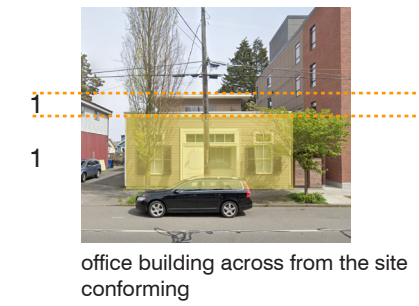
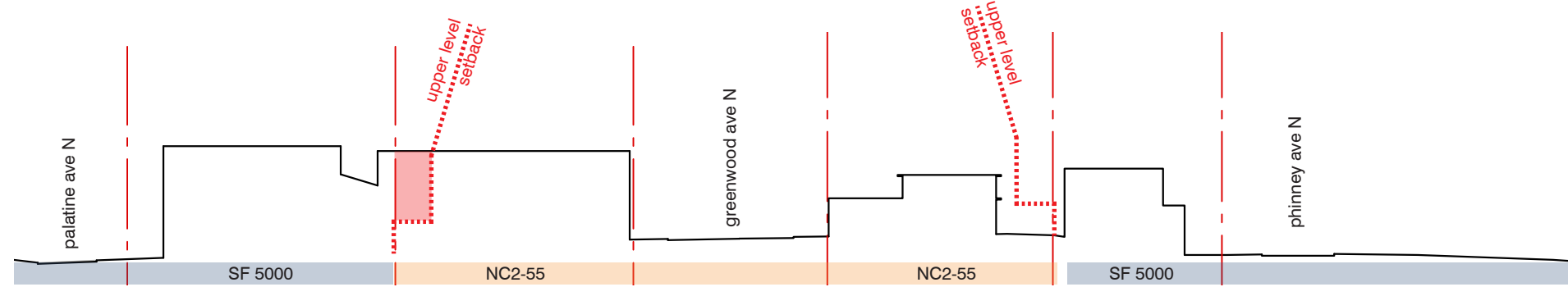
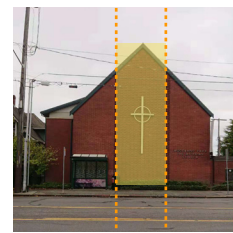
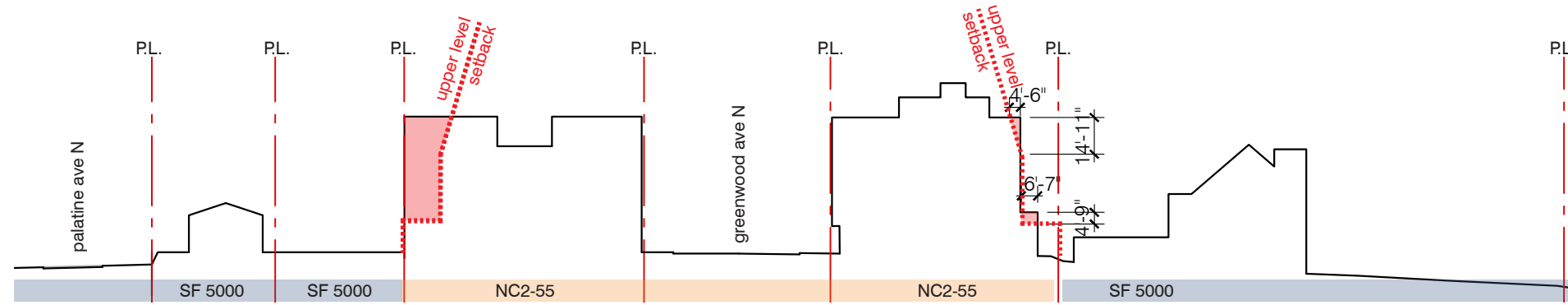

design guidelines

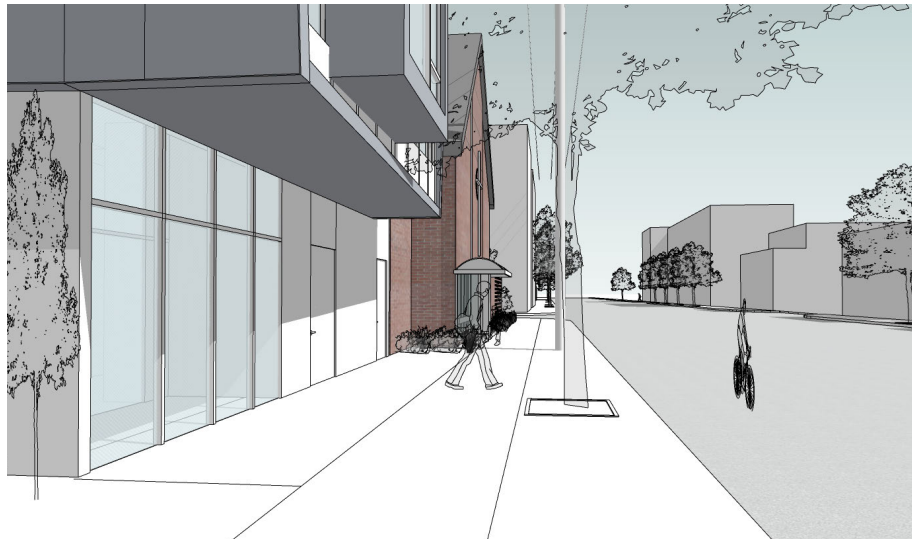

street edge

The midblock location of the site provides an opportunity for the project to bridge between the Fini Condominiums, the Church and the new development on the north side of 70th. By recessing the ground floor, the street-facing facade responds to the first floor datum that is typical for the neighborhood while creating a transitional entry space for the residential entry. This widening of the public realm provides covered outdoor space and additional opportunities for landscaping and urban elements like benches. Transparency at the residential entry will connect that lobby to the public realm and high quality material will provide a strong representation of a “base” to the project.

CS2.B.2 connection to street

CS2.C.2 mid-block sites

PL1.B.3 pedestrian amenities

PL2.B.3 street-level transparency

PL2.C.1 locations and coverage

Greenwood/Phinney Supplemental:

CS2.I.i.b Reinforcement of Residential Development

CS2.II.i impact of new buildings on the street

DC2.I facade articulation and modulation

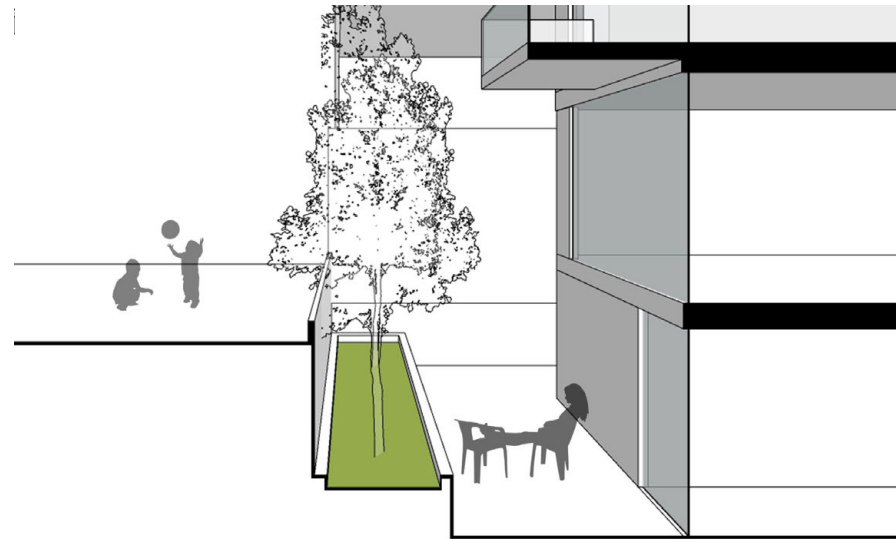

topography

By shaping the topography of the rear yard, the project will be able to integrate bioretention, landscaping and terraces that are vertically separated from the adjacent yard. The topographic change will create a sunken garden that serves as a soft transition to the neighboring building to the west. The garden will enhance the ground level privacy between the lots, introduce open space and landscaping and explore new ways to add positive outdoor space.

CS2.B.1 site characteristics

CS3.A.4 evolving neighborhoods

CS2.D.5 respect for adjacent sites

DC3.B.4 multifamily open space

DC4.D.4 place making

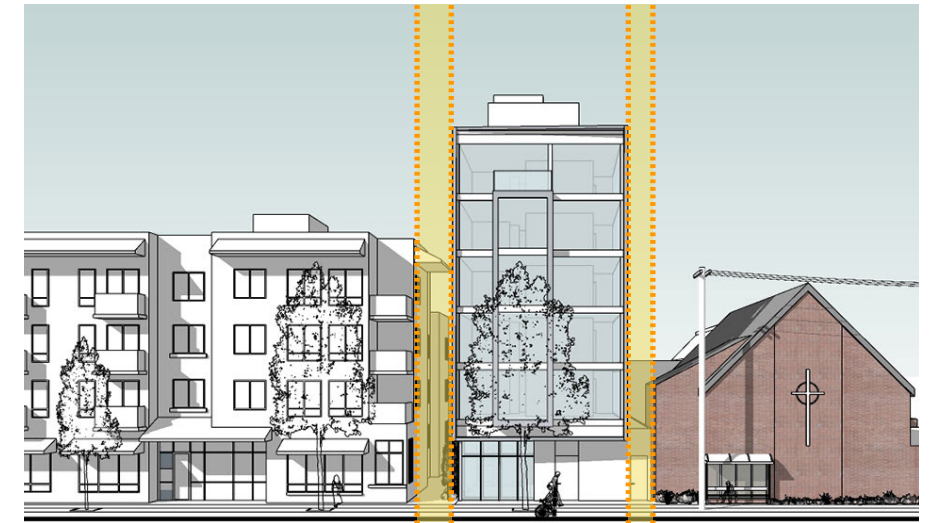

edges

A uniform setback on the north side provides an opportunity to maintain “space” between the project and the Church. This space provides daylight to the sanctuary, access for maintenance, and preserves the architectural presence and character of the existing brick structure. Private and subdued, the north wall becomes a backdrop to the Church with limited openings. Similarly, the south party wall can become a well-considered backdrop to the Fini Condominiums. The east and west facades can then be much more open to the view and street; fully connecting the dwellings to their context. Secondary elements like balconies and bays create depth and allow for more immediate engagement between the occupant and the context.

CS2.A.1 sense of place

CS2.A.2 architectural presence

CS2.B.1 site characteristics

CS2.B.2 connection to street

DC2.B.1 façade composition

Greenwood/Phinney Supplemental:

CS2.II.i zone edges

CS2.VII mass and scale



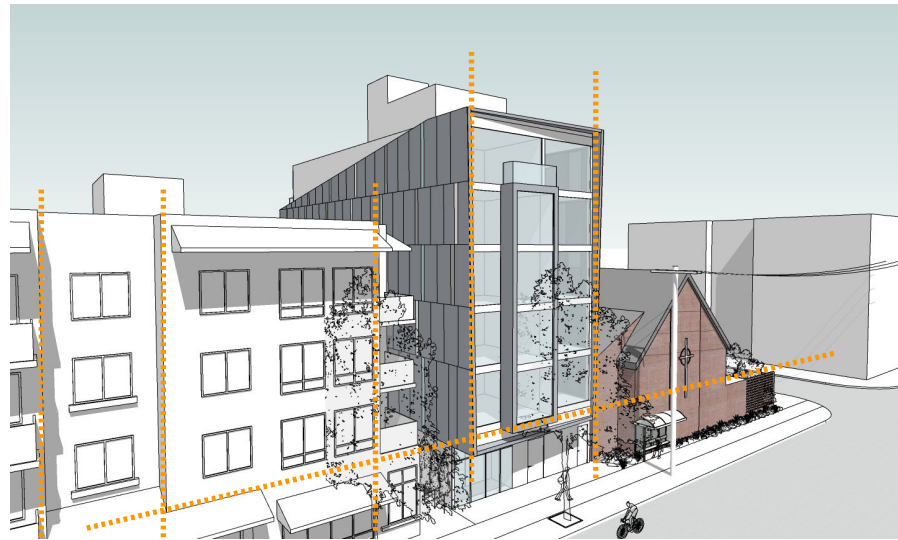

proportion and datums

The small, midblock site provides an opportunity to explore a uniquely scaled project type within a transitional setting. Taller than it is wide, the overall massing of this project will be smaller than its recently built neighbors. With limited frontage to work with, clean building forms, small scale modulation and projections, and considered detailing that echo the proportions and datums of the neighborhood can tie the project to both its smaller and larger neighbors.

- CS2.B.1 site characteristics**
- CS2.B.2 connection to street**
- CS2.D.3 zoning transitions**
- CS2.D.5 respect for adjacent sites**
- DC2.A.2 reducing perceived mass**

- Greenwood/Phinney Supplemental:**
- CS2-II.i impact of new buildings on the street**
- CS2.V street pattern**
- CS2.VII mass and scale**
- DC2.I facade articulation and modulation**

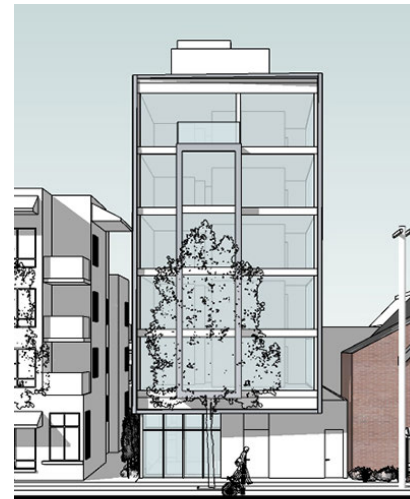

east side / west side

The dramatically different condition of the street side and the western view side provides an opportunity for the project to present two faces to the neighborhood. Perceived height, environmental controls, visual connections, outdoor spaces, privacy, and relationships to our adjacent neighbors will drive different design responses for each side.

- CS2.A.2 architectural presence**
- CS2.D.5 respect for adjacent sites**
- CS3.A.4 evolving neighborhoods**
- DC2.C.1 visual depth and interest**
- DC2.D.2 texture**

- Greenwood/Phinney Supplemental:**
- CS1.I responding to site characteristics**
- CS2.II.ii design departures**
- DC2.I facade articulation and modulation**



integration of elements

Through a synthesis of contextually responsive massing, secondary architectural elements, and environmental systems and controls, that project has an opportunity to present an integrated approach to design elements. Driven by the small site, compact form and limited roof area the project will need to creatively develop strategies for design elements to serve multiple purposes. These elements will provide a thoughtful response for the project's relationship to the context and neighbors, the resident's quality of life, energy generation and use, and environmental systems.

- CS1.A.1 energy choices**
- CS.B.2 daylight and shading**
- CS2.B.1 site characteristics**
- CS2.D.2 existing site features**
- PL4.B.2 bike facilities**
- DC2.C.2 dual purpose elements**
- DC3.C.3 amenities and features**
- DC4.A.1 exterior finish materials**



architectural concepts

concept A (code compliant)// terrace

The form of Terrace reflects a direct interpretation of the allowable zoning envelope. The ground floor of the project extends to the north lot line and abuts the Church along its entire length. At the west side it is set back five feet to provide daylight to ground level units. Above the ground floor, the building steps 15 feet for the next three stories. At levels five and six it makes additional steps in form to conform to an increasing setback above 40 feet. At each setback, the roof becomes a terrace that expands the livable area of the project and dwelling units. There is no roof deck at the top level, instead, the roof of the first floor provides outdoor amenity area for the project. At street level, the building extends to the property line with a projecting canopy to define a street level datum. Bike storage, waste storage, and the residential entry all front Greenwood Avenue North.

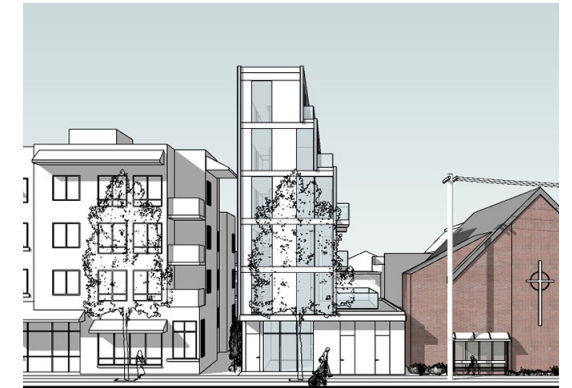
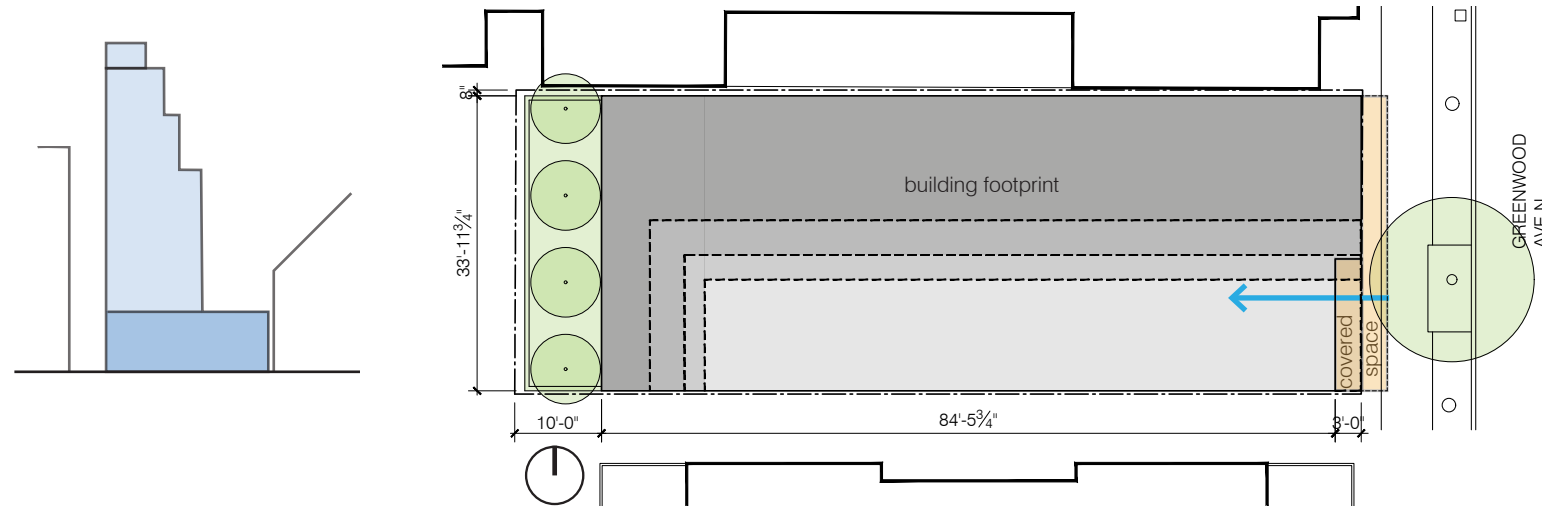

concept B // push + pull

The massing of Push+Pull seeks to create a continuous street frontage while providing a setback for the clerestory windows of the Church sanctuary and south wall. The street-facing facade is articulated in five parts; base, body, penthouse, roof, and slot. The Base is set back 6 feet from the street lot line and 3'-11" from the north. This expands the public realm, creates a strong ground level datum, and provides access along the north lot line to egress, bike storage and the south wall of the Church. The Body contains levels two through five and extends over the base providing covered outdoor space and a passage on the north. The Penthouse is setback from both the street and north lot line to introduce a strong upper-level datum. The Roof projects over this setback and wraps down the south side as a building skin that defines the edge of the Slot—which introduces additional modulation to the façade.

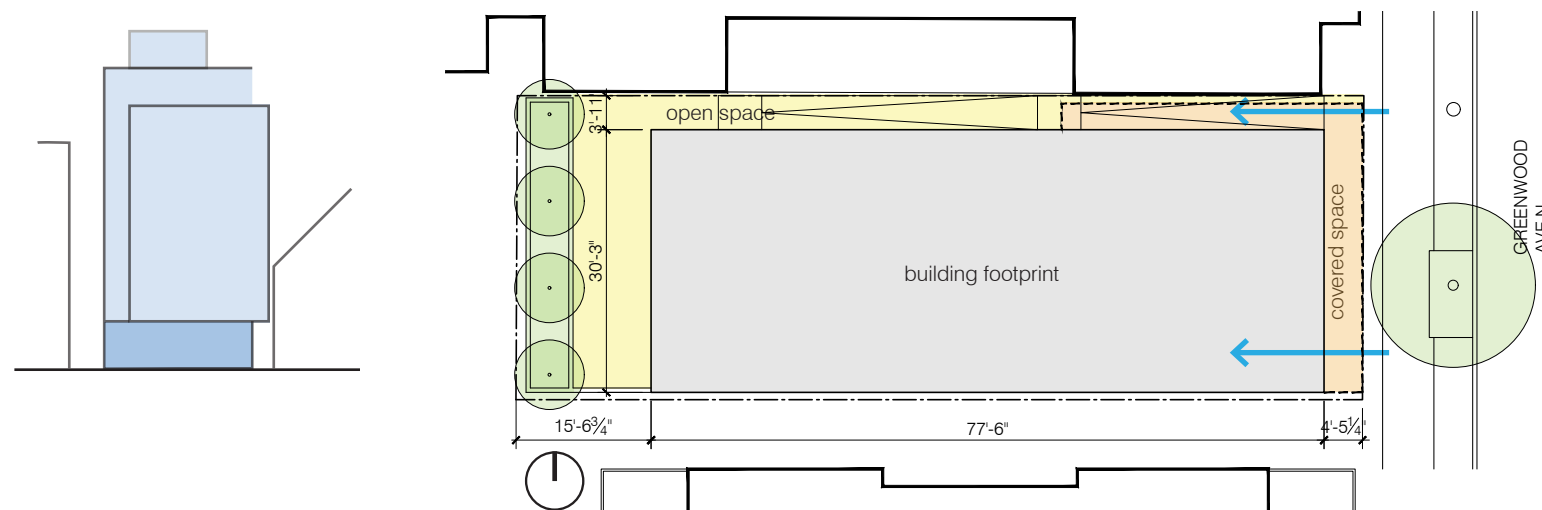

concept C (preferred) // uniform yard

With a narrower frontage that has an open space on each side, Uniform Yard presents a simple building form. The street-facing facade is articulated in four parts; base, facade, frame and bay. The Base is set back 6 feet from the street lot line and five feet from the north. This expands the public realm, creates a strong ground level datum, and provides access along the north lot line to egress, bike storage and the south wall of the Church. The Façade contains levels two through six and extends over the base providing covered outdoor space at the residential entry. It is primarily transparent creating a strong connection between the dwellings and the public realm. The Frame projects forward to create depth within the façade and integrate the north and south walls into the primary form. The Bay creates a secondary façade element that reduces the perceived height and scale of the façade.

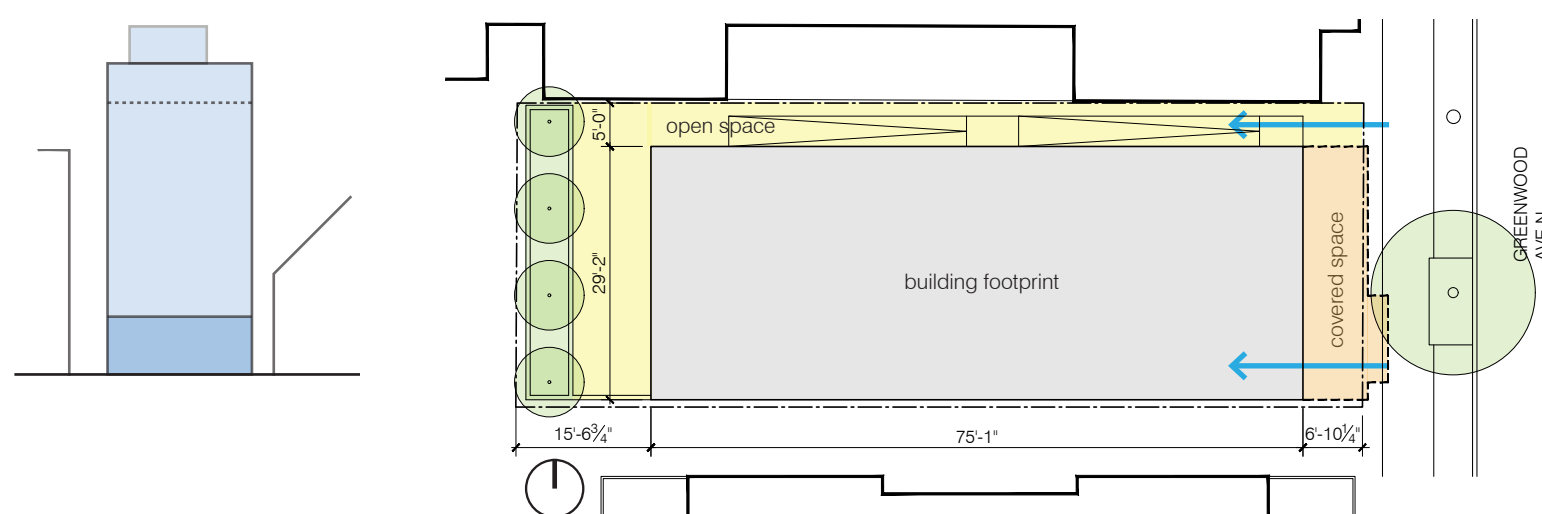

Advantages

- No departures required
- Convenient bike storage
- No trash staging in the ROW required
- Greatest setback at upper levels

Disadvantages

- Limited massing articulation along Greenwood Ave North due to no setback at street level
- Limited landscape opportunity at street level
- Limited private outdoor space
- Limited unit diversity
- Challenging unit layouts
- No access to south wall of Church

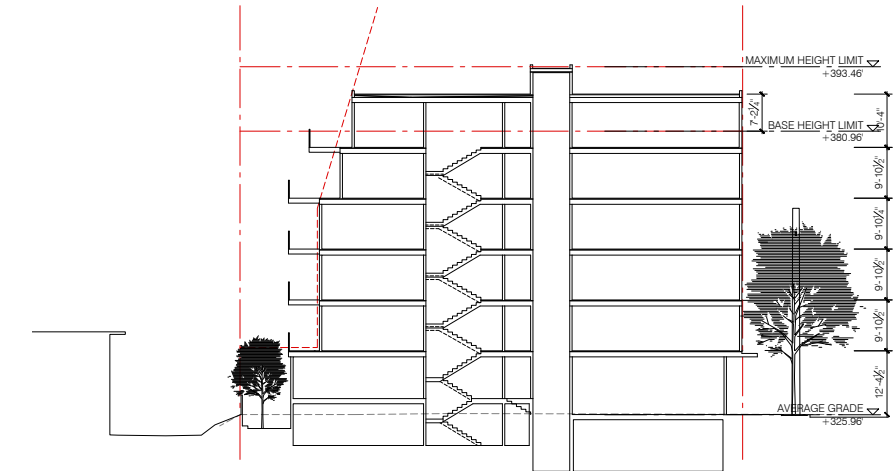

Advantages

- Exterior access to bike storage
- No trash staging in the ROW required
- Expanded outdoor space at street level
- Strong connections to view on east and west façade
- Most façade articulation
- Reduced perceived height at east and west side
- Roof deck set away from roof edge
- Widest back garden
- Most unit type and size diversity
- Greatest amount of building area

Disadvantages

- Departures required
- Abuts portion of Church, limiting access for maintenance and roof drainage
- Ramp up to bike room creates additional coverage of Church wall
- Least amount of upper-level setback
- Most bulk on west side

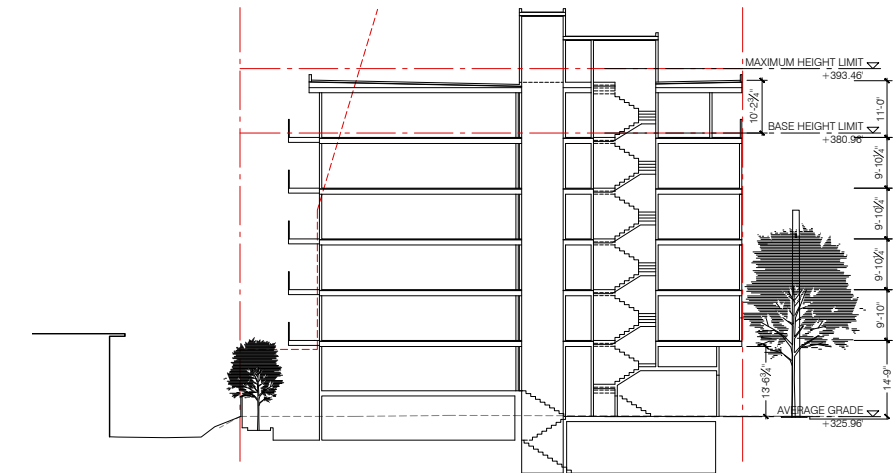

Advantages

- Convenient bike storage
- Ramp down preserves access to Church wall
- No trash staging in the ROW required
- Expanded outdoor space at street level
- Uniform setback from north property line
- Church has full access to their south wall
- Strong connections to view on east and west façade
- Reduced mass at west side
- Reduced perceived height at west side
- Reduced perceived height at east side
- Widest back garden
- Roof deck set away from roof edge

Disadvantages

- Departures required
- Narrow lobby
- Less unit diversity
- Less total floor area

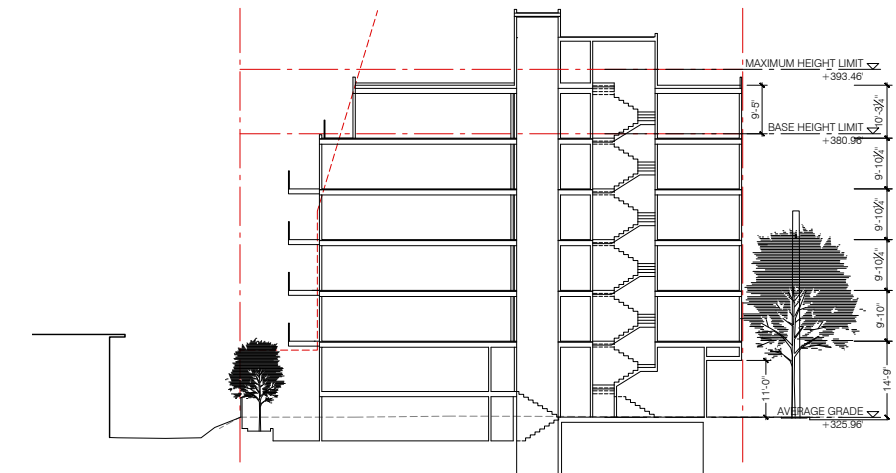

concept A (code compliant)// terrace

Terrace presents a design response that is shaped by the zoning code requirements for upper-level setbacks. When a commercial zone abuts a single family zone, an upper level setback of 15 feet is required for portions of the building that are higher than 13 feet above grade. This is normally required at only lot lines that abut a single family zone, the west lot line, however, since the Church is on a single lot that spans across the zone transition it is required on the north lot line as well due to a unique situation. The portion of the Church lot that is zoned single family is more than 50% of the lot width. When this happens, the requirements of the single family zone extend to the commercially zoned portion of the lot.

The form of Terrace reflects a direct interpretation of the allowable zoning envelope. The ground floor of the project extends to the north lot line and abuts the Church along its entire length. At the west side is it set back five feet to provide daylight to ground level units. Above the ground floor, the building steps 15 feet for the next three stories. At levels five and six it makes additional steps in form to conform to an increasing setback above 40 feet. At each setback, the roof becomes a terrace that expands the livable area of the project and dwelling units. There is no roof deck at the top level, instead, the roof of the first floor provides outdoor amenity area for the project. At street level, the building extends to the property line with a projecting canopy to define a street level datum. Bike storage, waste storage, and the residential entry all front Greenwood Avenue North.

Lot Area	3,413
Stories	6
Height	62 ft
FAR (base)	3.25
GFA (Base allowed)	12,797 sf
GFA (LBC allowed)	15,996 sf
GFA (proposed)	10,455 sf
Amenity Area	842 sf
Units	18
Ave Size	465 sf

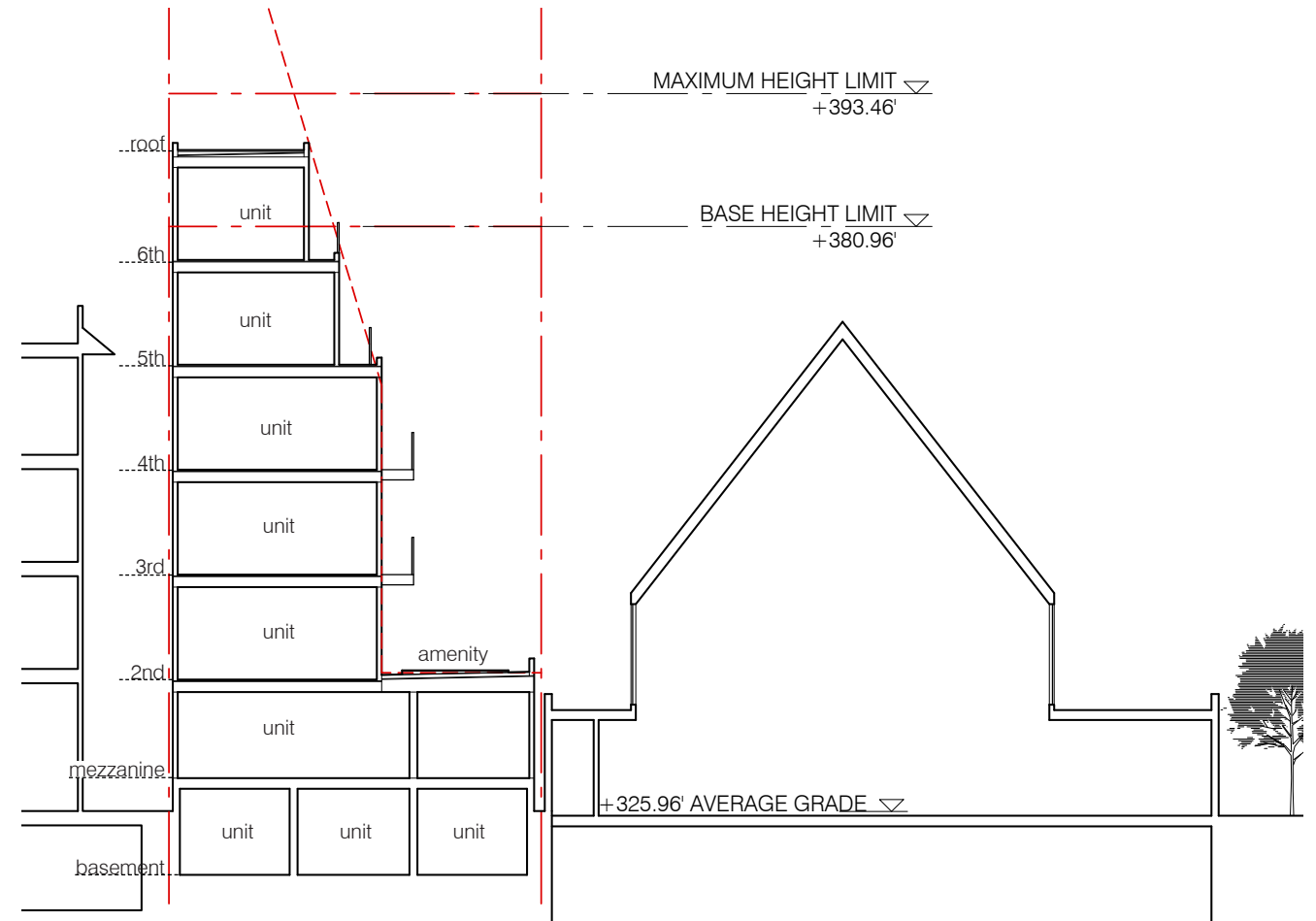

cross section



east elevation



west elevation



street view // northeast



street view // southeast

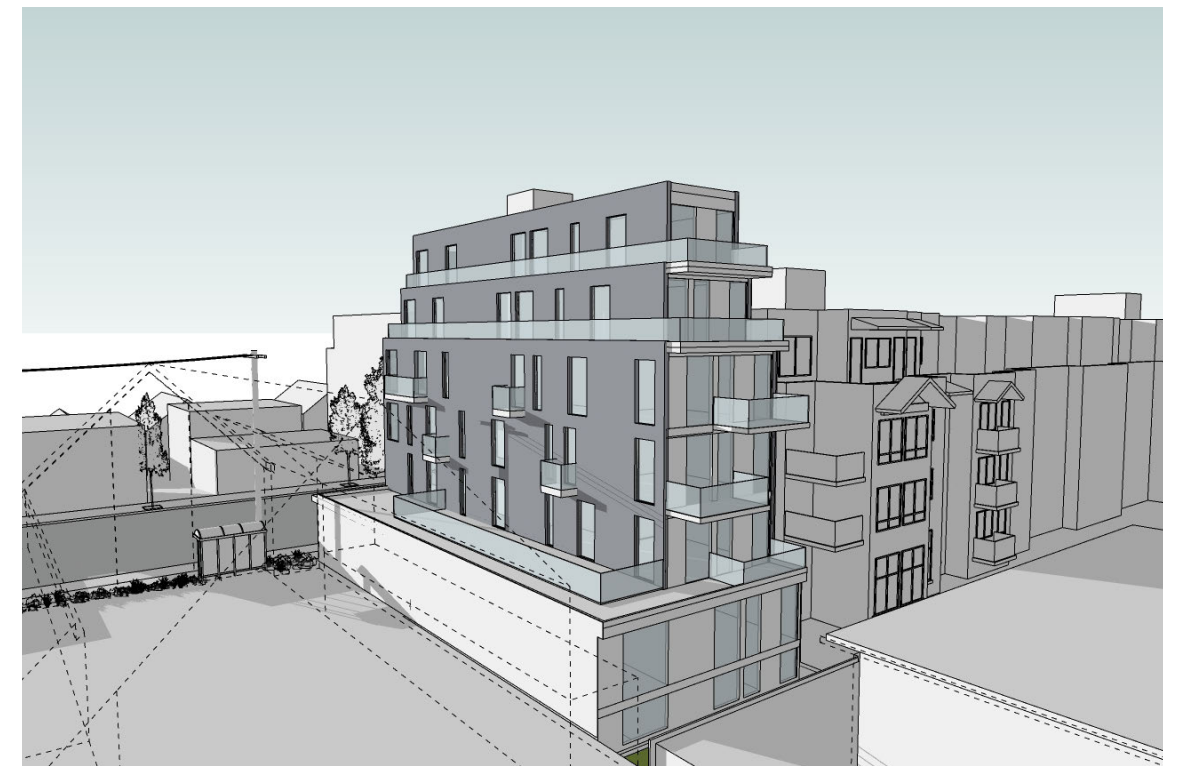

rear view // northwest

note: Church shown in dash line

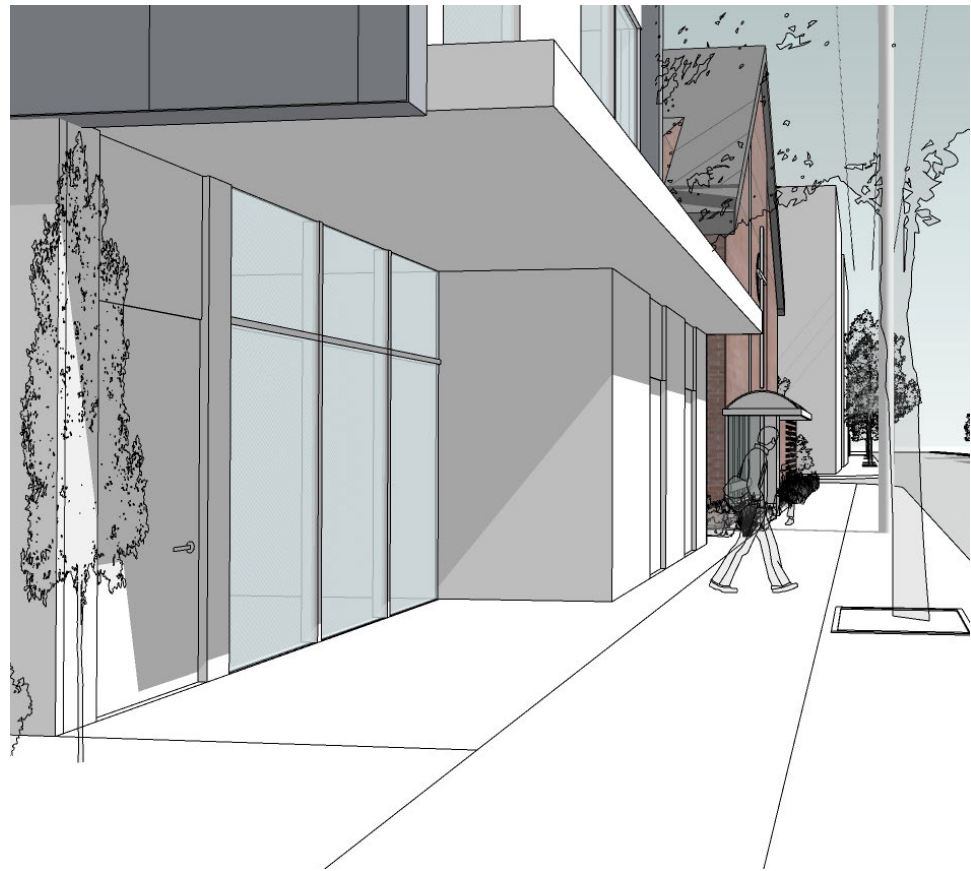

sidewalk

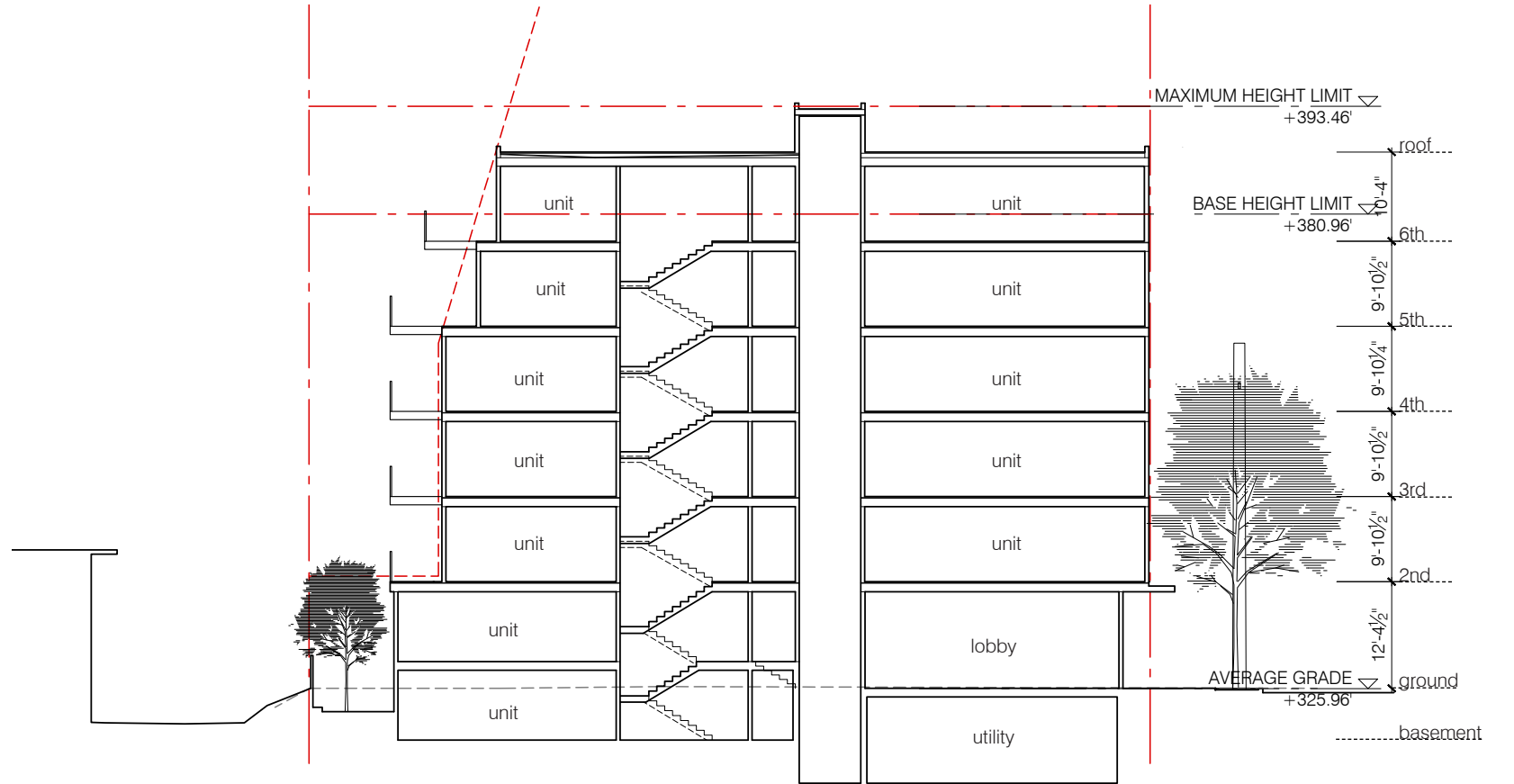

longitudinal section

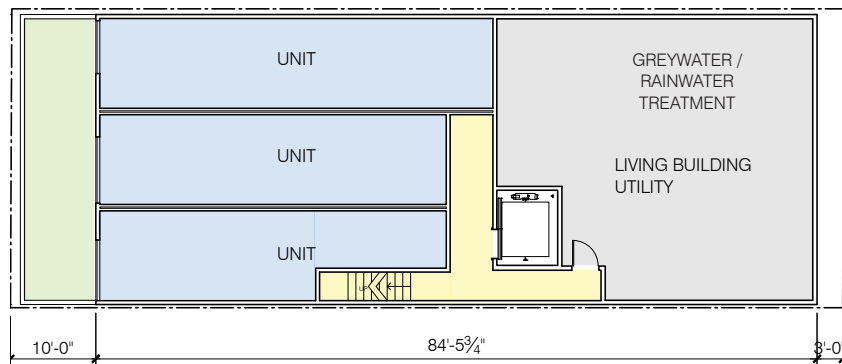

basement // 3 units

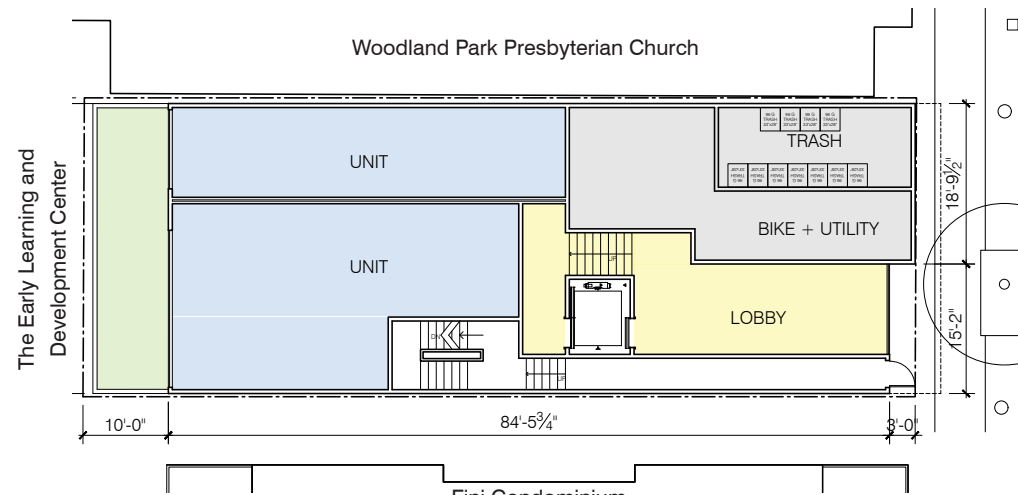

ground floor // 2 units

Fini Condominium

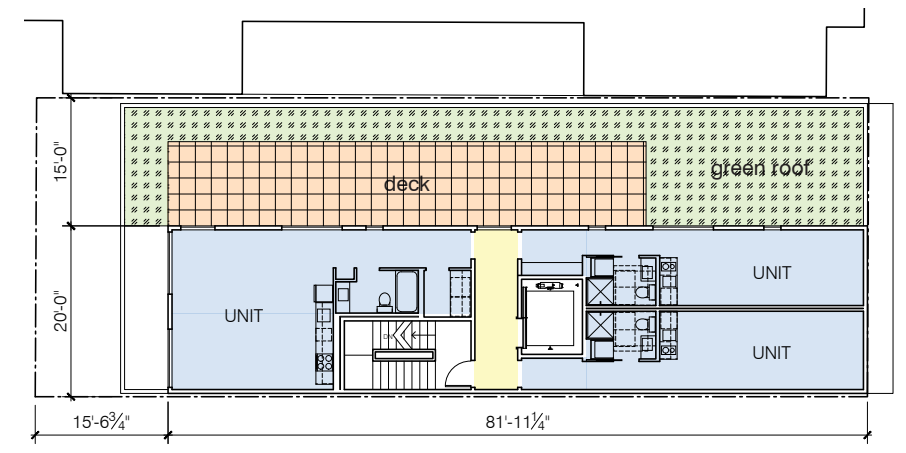

2nd-3th floor // 3 units



southeast front view



northeast birdeye



southwest birdeye

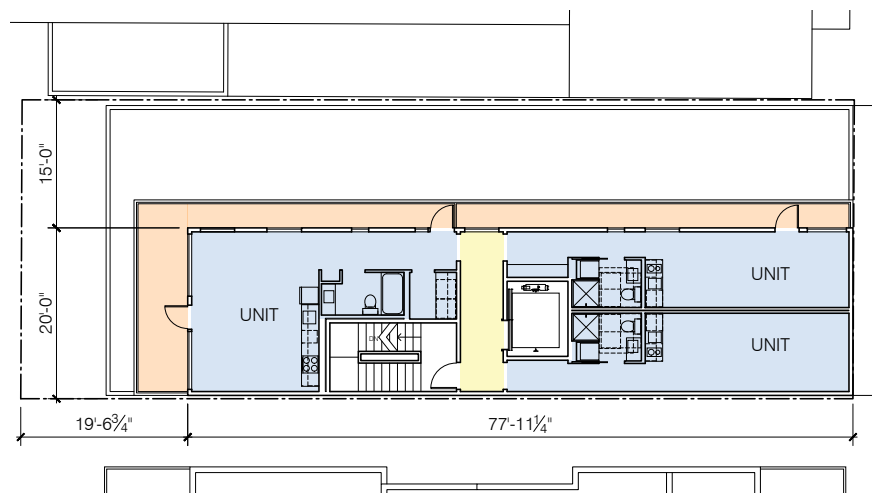

5th floor // 3 units

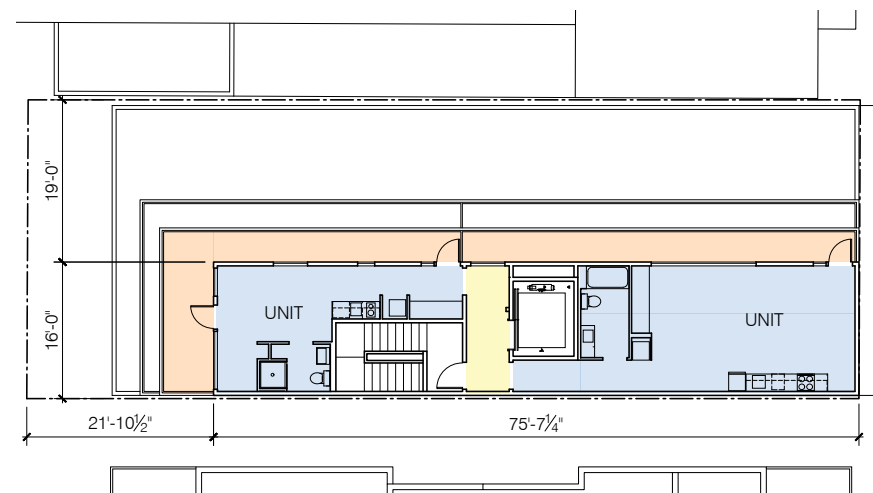

6th floor // 2 units

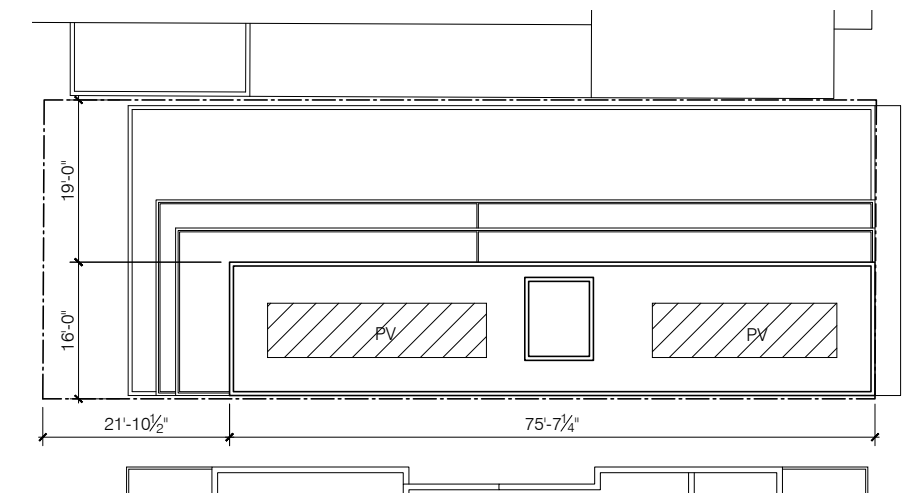

roof

concept B // push + pull

The massing of Push+Pull seeks to create a continuous street frontage while providing a setback for the clerestory windows of the Church sanctuary and south wall. The street-facing facade is articulated in five parts; base, body, penthouse, roof, and slot. The Base is set back 6 feet from the street lot line and 3'-11" from the north. This expands the public realm, creates a strong ground level datum, and provides access along the north lot line to egress, bike storage and the south wall of the Church. The Body contains levels two through five and extends over the base providing covered outdoor space and a passage on the north. The Penthouse is setback from both the street and north lot line to introduce a strong upper-level datum. The Roof projects over this setback and wraps down the south side as a building skin that defines the edge of the Slot—which introduces additional modulation to the façade.

These elements carry around the project and return to the west side. Given the split-level section of the ground floor, the Base is now two stories high. The Body encloses exterior view facing covered balconies that project into the upper-level setback. The Penthouse appears to be set back five feet from the projecting balconies. The Roof, again, turns down the south façade to provide additional screening between the balconies and the Fini Condominiums. The roof is covered by a common roof deck, vegetation, and solar panels. The garden creates a landscaped buffer between the early learning development center and the project; providing privacy for the basement level units. The north and south walls are backdrops to their neighbors and will present a tapestry-like composition of panels and openings on the north and panels and accents on the south.

Lot Area	3,413
Stories	6
Height	64.5 ft
FAR (base)	3.25
GFA (Base allowed)	12,797 sf
GFA (LBC allowed)	15,996 sf
GFA (proposed)	13,938 sf
Amenity Area	692 sf
Units	25
Ave Size	492 sf

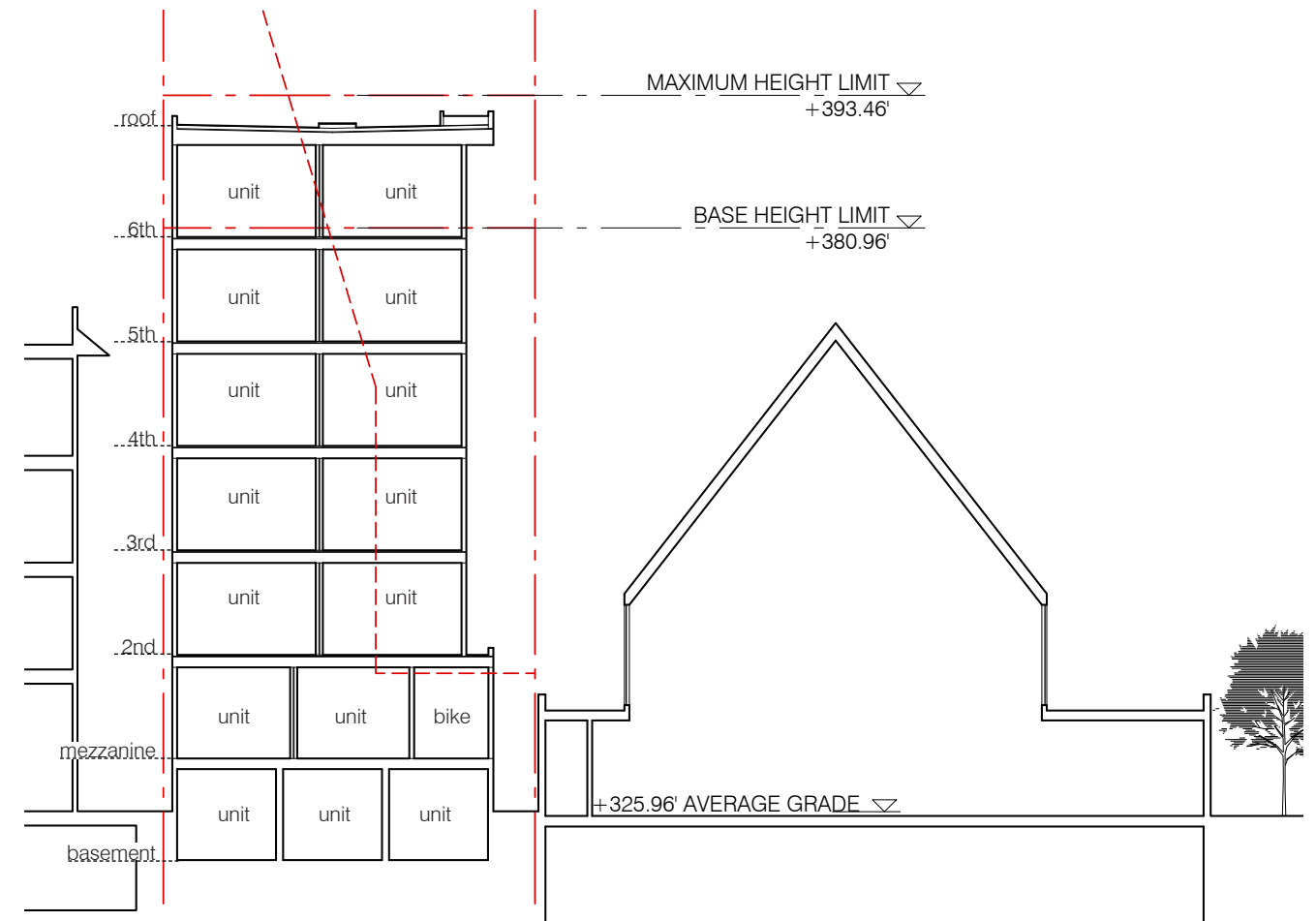

cross section



east elevation



west elevation



street view // northeast



street view // southeast

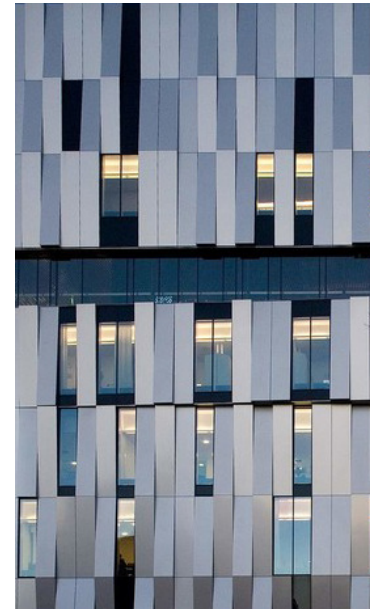

panel facade



rear view // northwest

note: Church shown in dash line

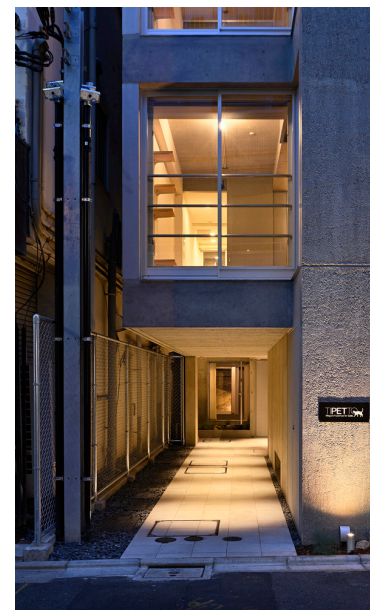

passage



sidewalk

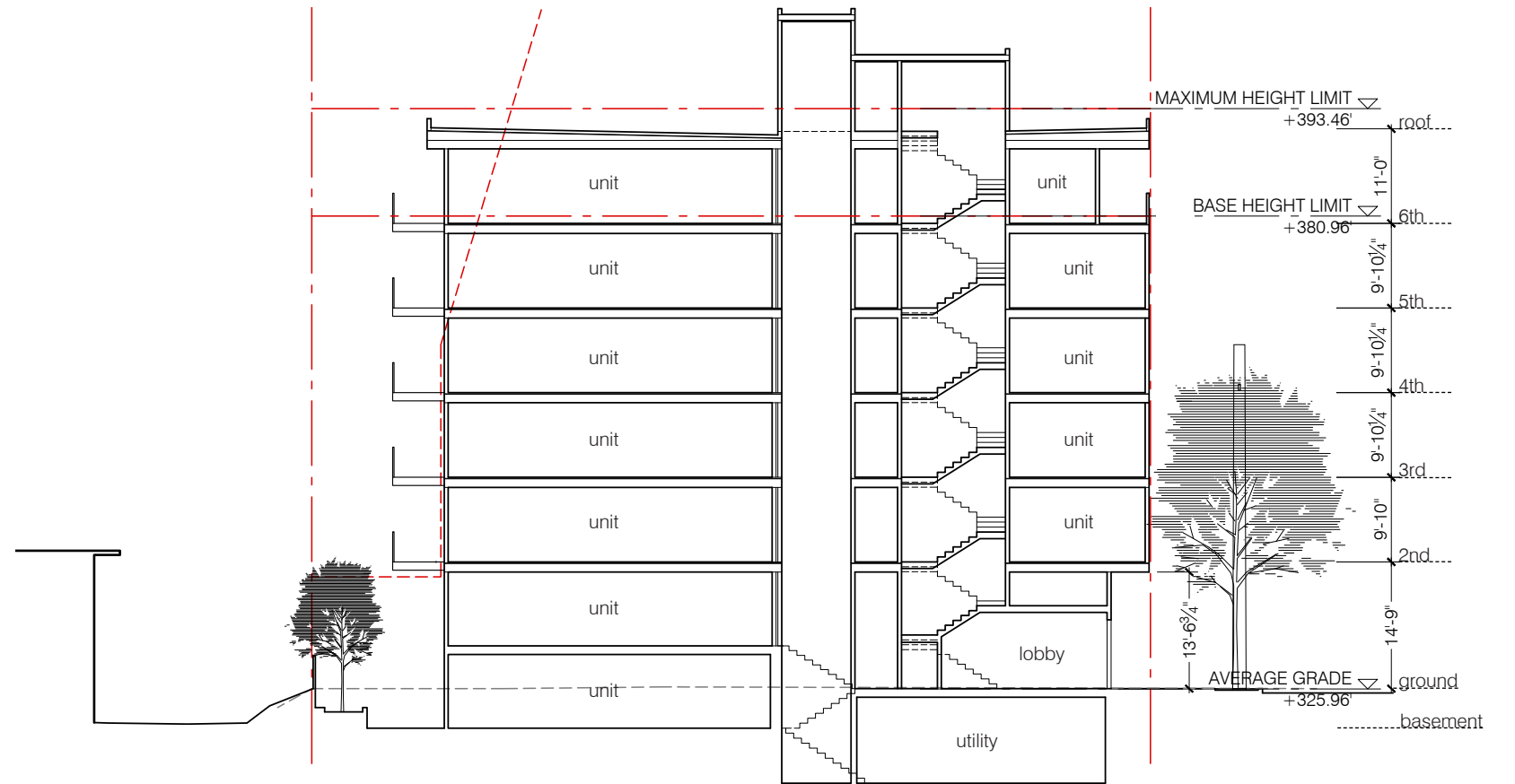

longitudinal section

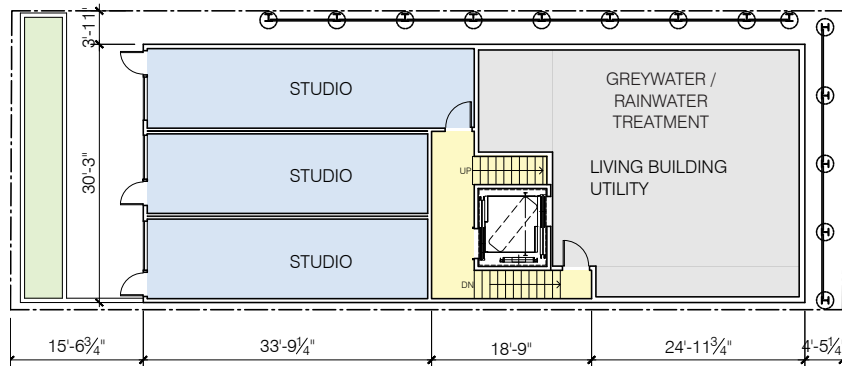

basement // 3 units

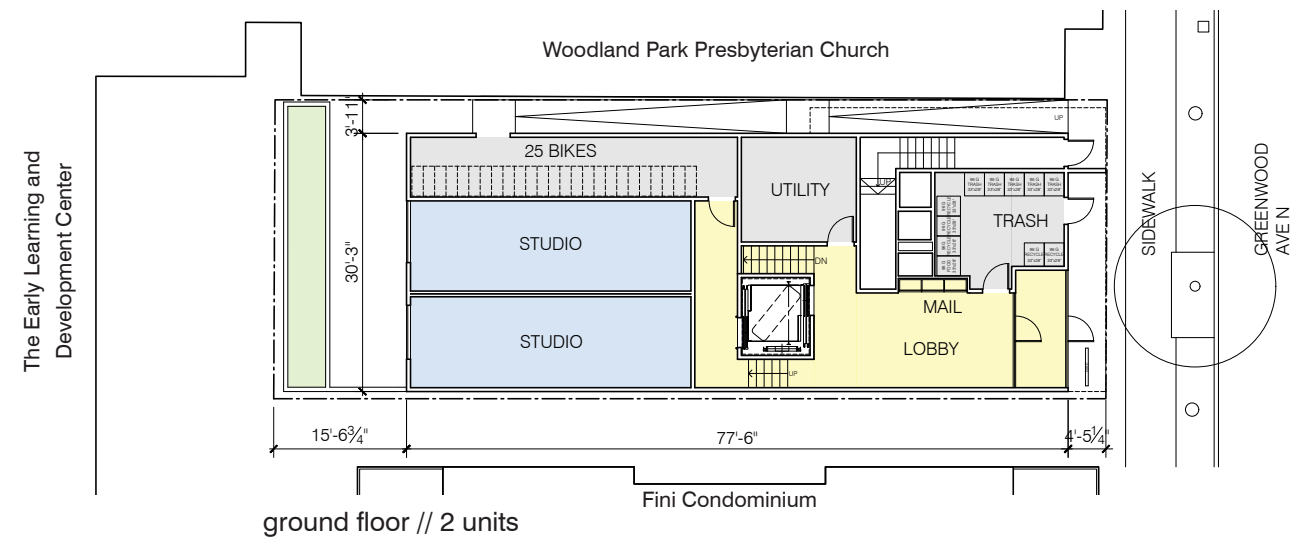

ground floor // 2 units



southeast front view



northeast birdeye



southwest birdeye

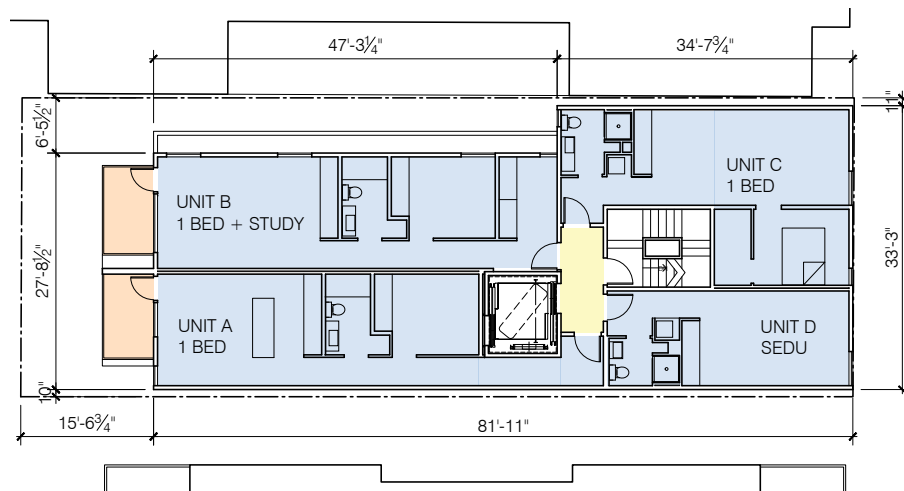

2nd-4th floor // 4 units

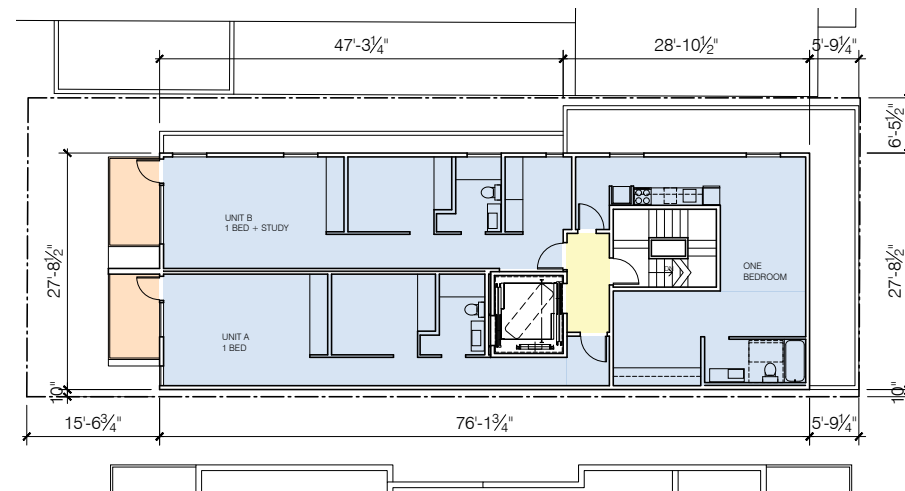

6th floor // 3 units

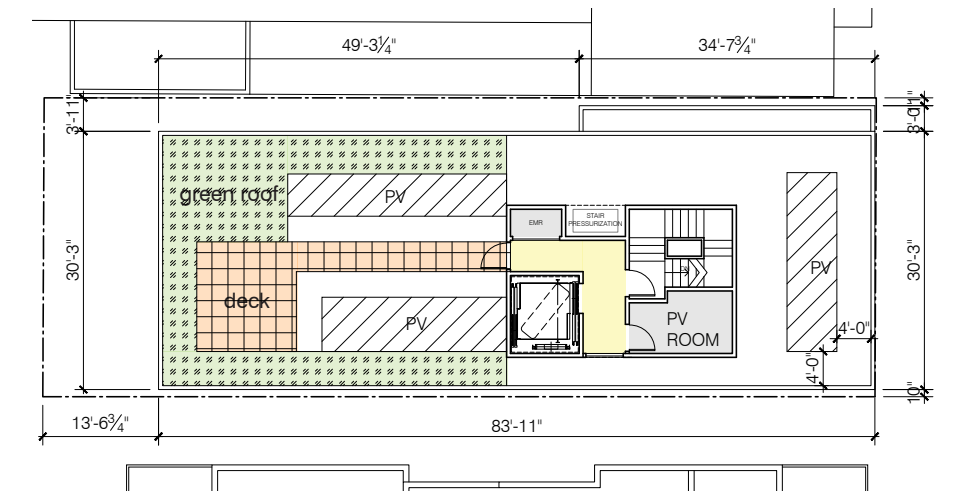

roof

concept C (preferred) // uniform yard

Over the past months, the design team has worked with the leadership of Woodland Park Presbyterian Church on different design strategies for the project. Uniform Yard represents the preferred design from these efforts. It provides a uniform setback along the shared lot line to create open space for the clerestory windows of the Church sanctuary and the entire south wall for long term access and maintenance.

With a narrower frontage that has an open space on each side, Uniform Yard presents a simple building form. The street-facing facade is articulated in four parts; base, facade, frame and bay. The Base is set back 6 feet from the street lot line and five feet from the north. This expands the public realm, creates a strong ground level datum, and provides access along the north lot line to egress, bike storage and the south wall of the Church. The Façade contains levels two through six and extends over the base providing covered outdoor space at the residential entry. It is primarily transparent creating a strong connection between the dwellings and the public realm. The Frame projects forward to create depth within the façade and integrate the north and south walls into the primary form. The Bay creates a secondary façade element that reduces the perceived height and scale of the façade.

These elements transform on the west side. Given the split-level section of the ground floor, the Base is now two stories high. The Façade is expressed up to level five where the project steps back to articulate a penthouse at the top floor. The Frame, again, encloses the Façade and projects to provide additional screening between the dwellings and the Fini Condominiums. In this case, the balconies, like the Bay, are secondary elements that project from the building. The roof is covered by a common roof deck, vegetation, and solar panels. The garden creates a landscaped buffer between the early learning development center and the project; providing privacy for the basement level units. The north and south walls are backdrops to their neighbors and will present a tapestry-like composition of panels and openings on the north and panels and accents on the south. The top of the wall slopes down from east to west, revealing the penthouse and lower scale of the west side.

Lot Area	3,413
Stories	6
Height	64.5 ft
FAR (base)	3.25
GFA (Base allowed)	12,797 sf
GFA (LBC allowed)	15,996 sf
GFA (proposed)	13,591 sf
Amenity Area	692 sf

Units	24
Ave Size	504 sf

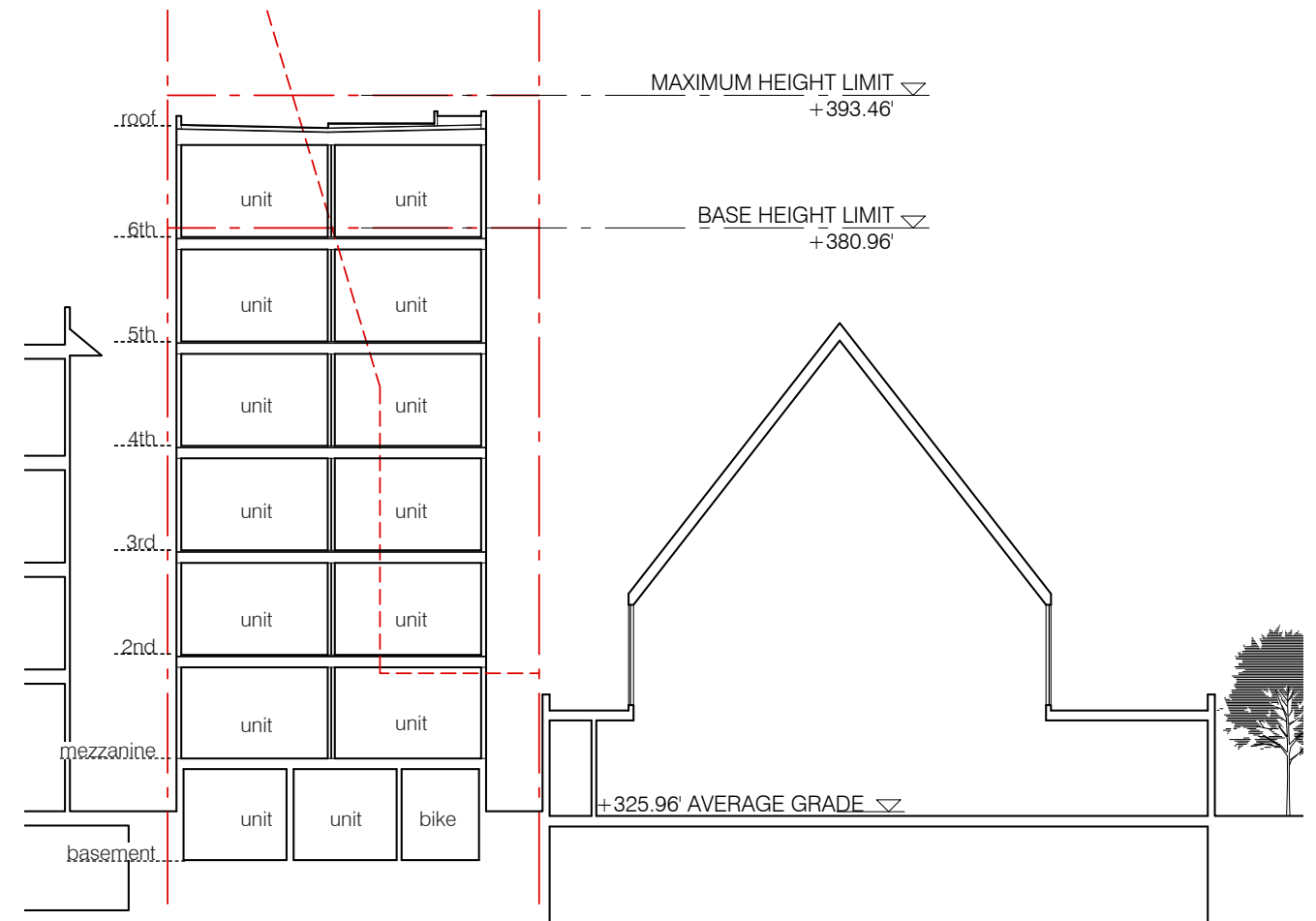

cross section



east elevation



west elevation



street view // northeast



street view // southeast

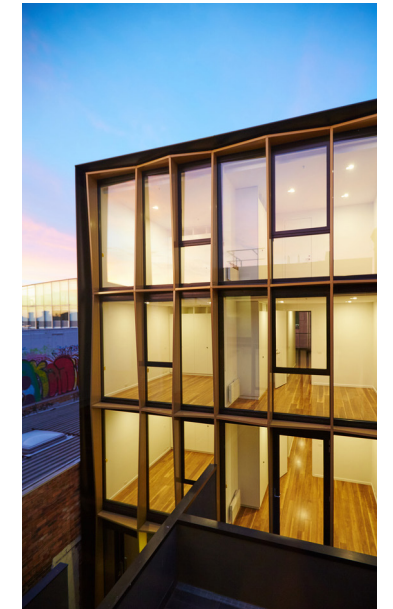

extended building skin



rear view // northwest

note: Church shown in dash line



modulated balconies

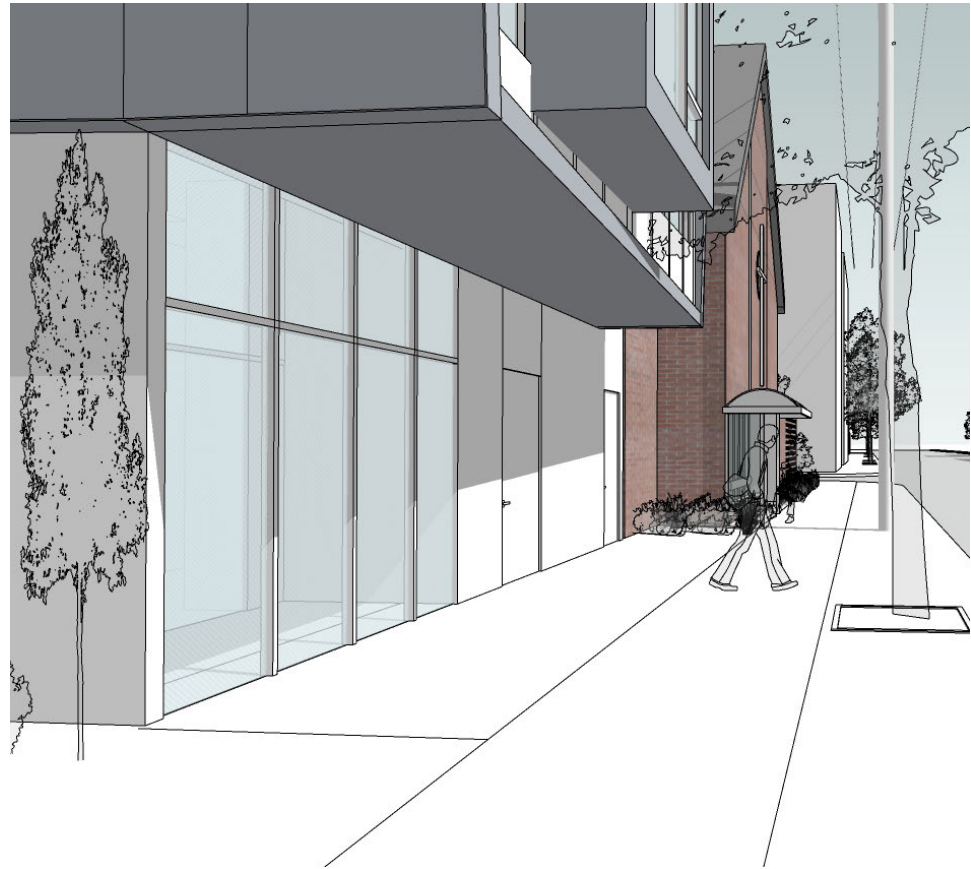

sidewalk

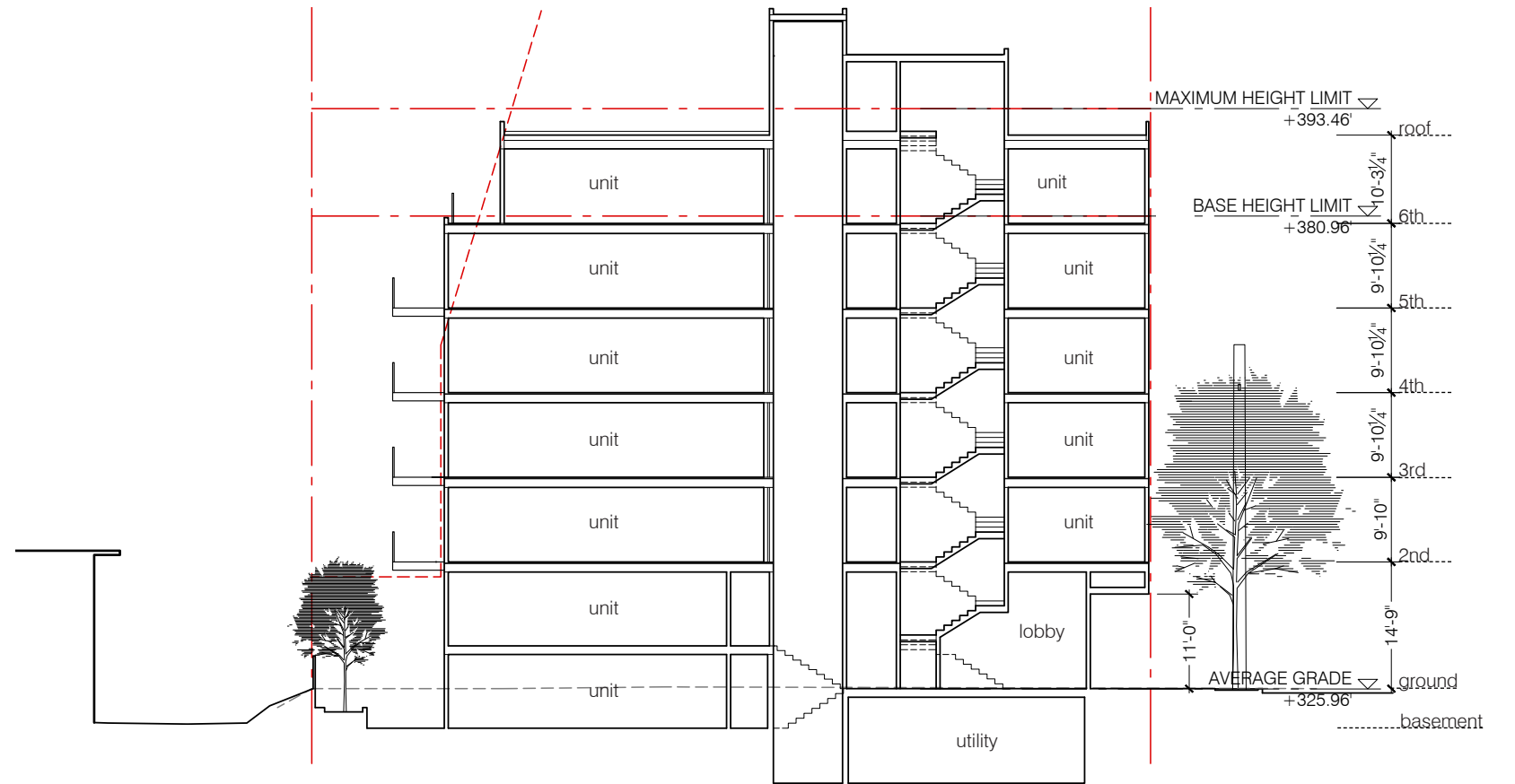

longitudinal section

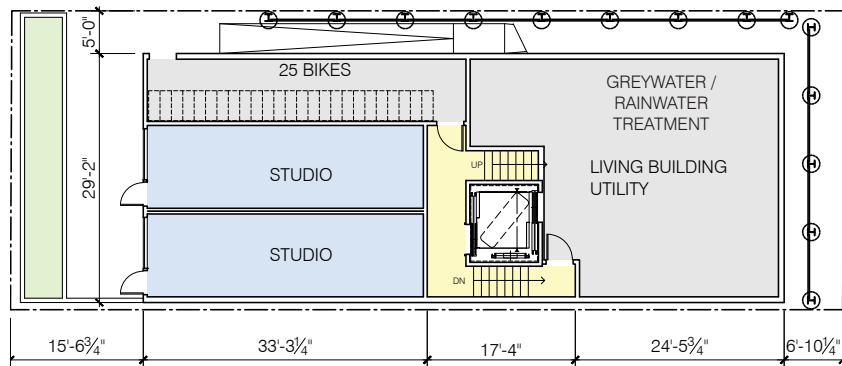

basement // 2 units

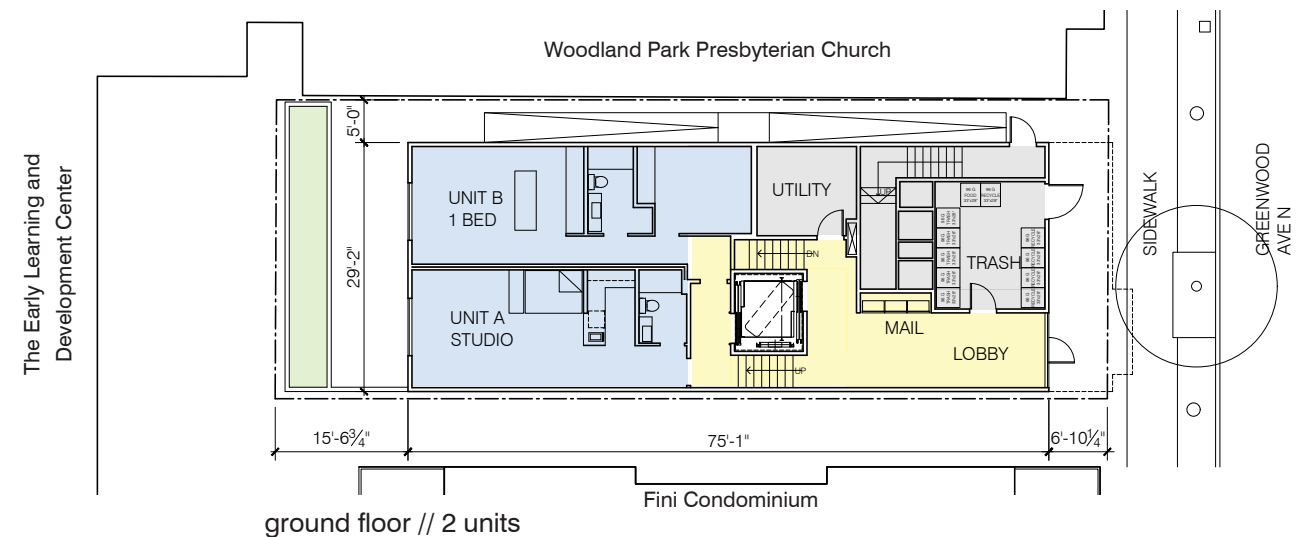

ground floor // 2 units



southeast front view



northeast birdeye



southwest birdeye

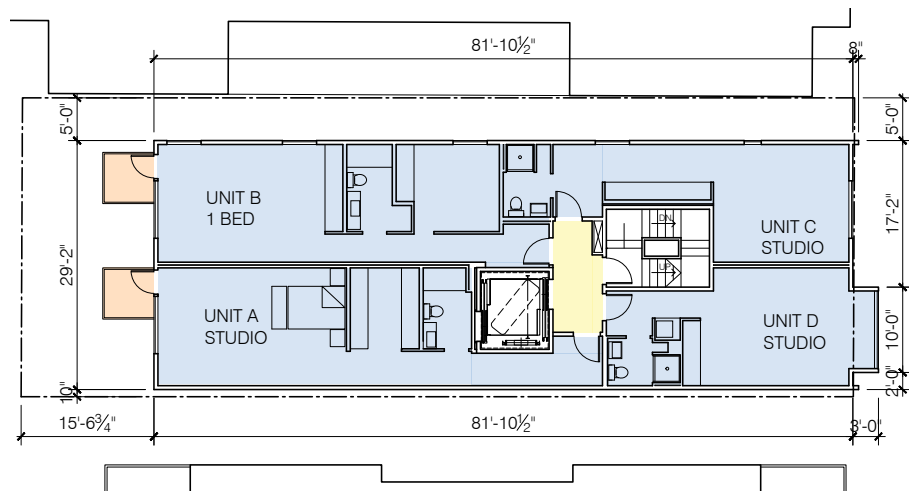

2nd-5th // 4 units

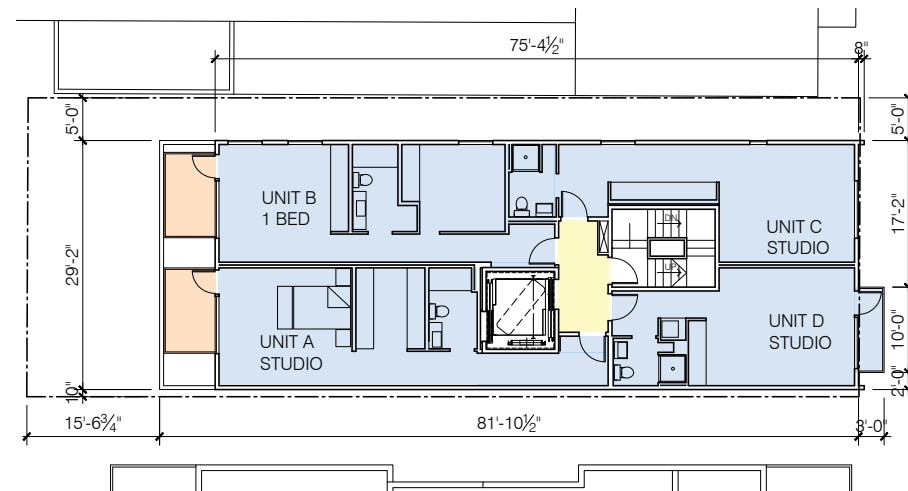

6th floor // 4 units

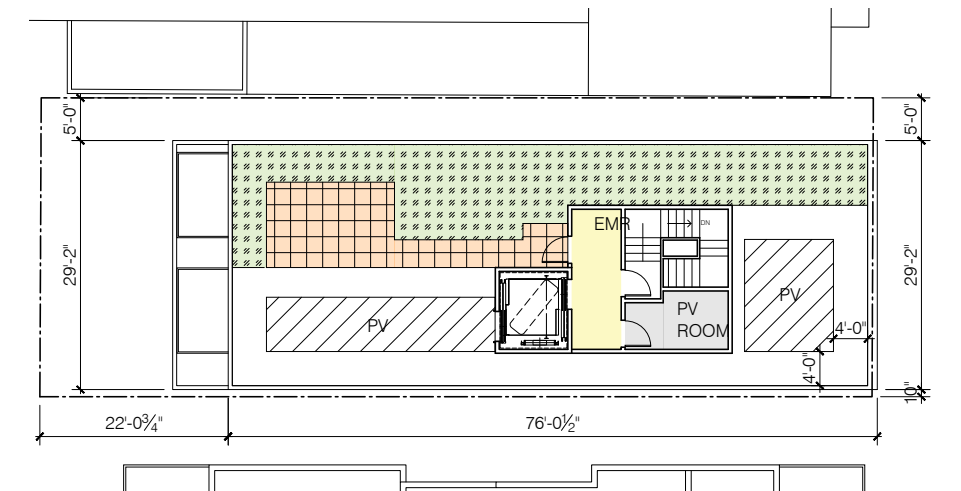

roof

shadow study

concept A (code compliant)// terrace

equinox

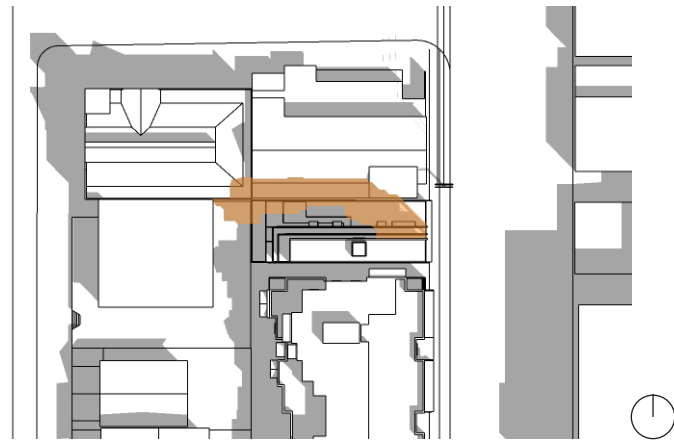

march/september 21
9 am

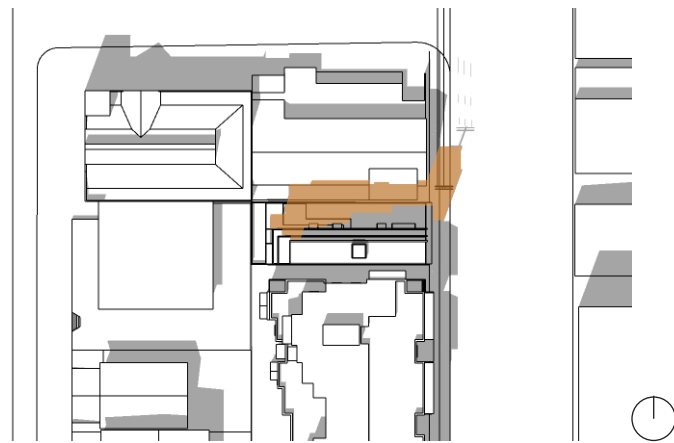

march/september 21
12 pm

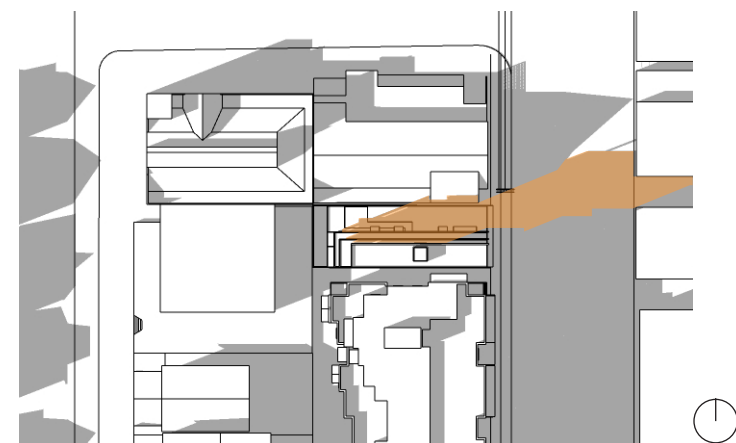

march/september 21
3 pm

summer

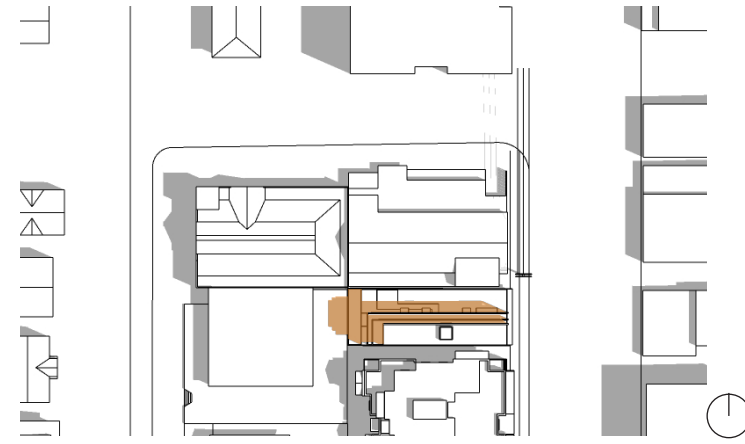

june 21
9 am

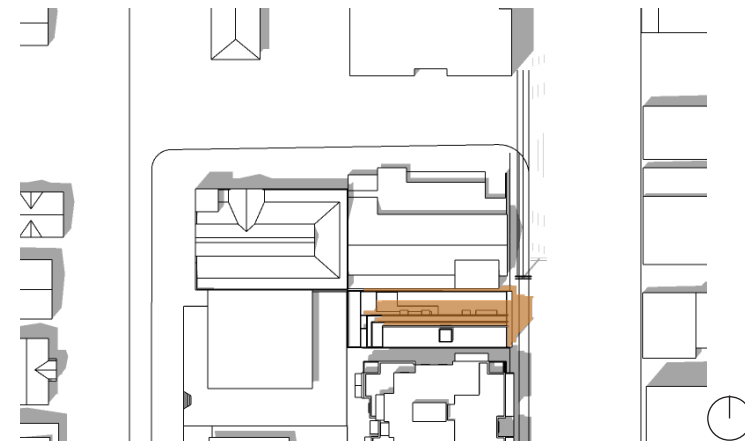

june 21
12 pm

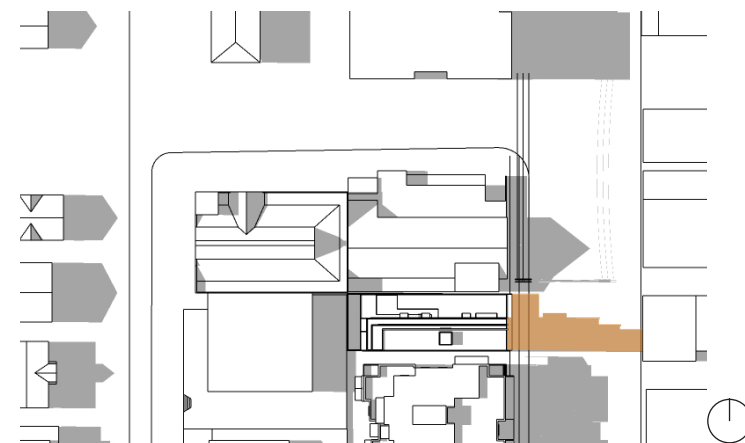

june 21
3 pm

winter

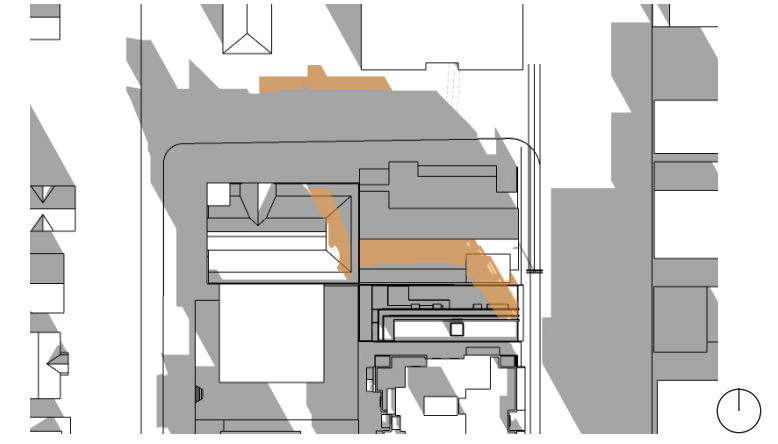

december 21
9 am

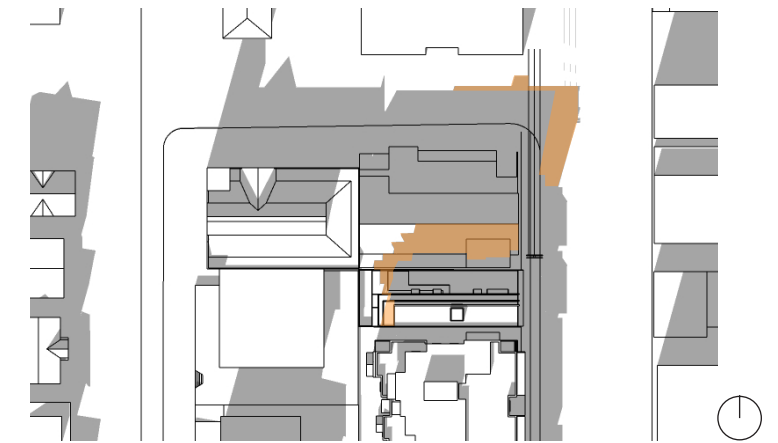

december 21
12 pm

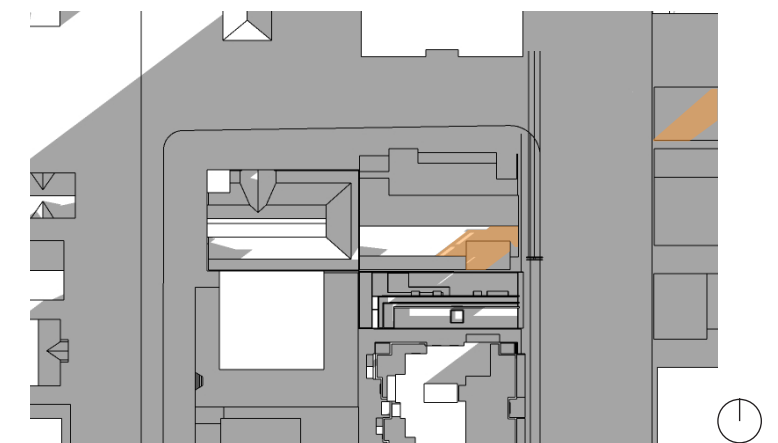

december 21
3 pm

concept B // push + pull

equinox

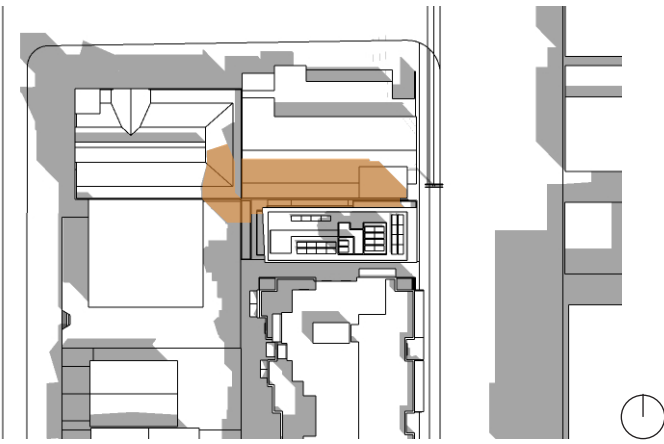

march/september 21
9 am

summer

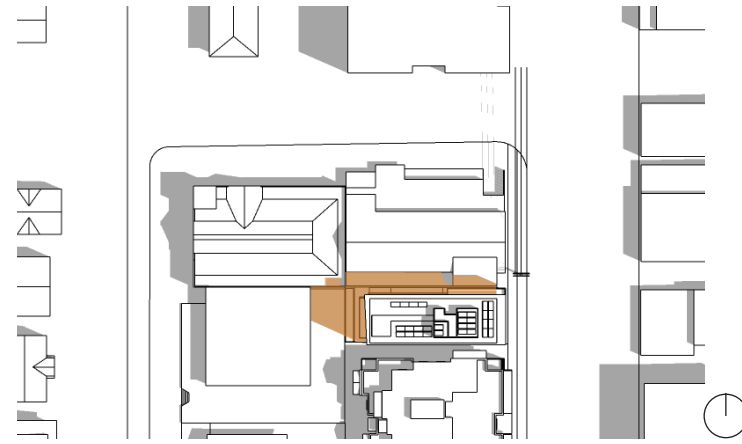

june 21
9 am

winter

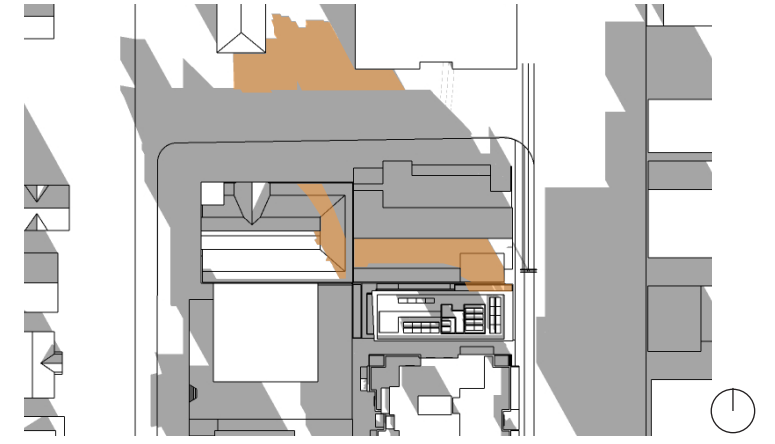

december 21
9 am

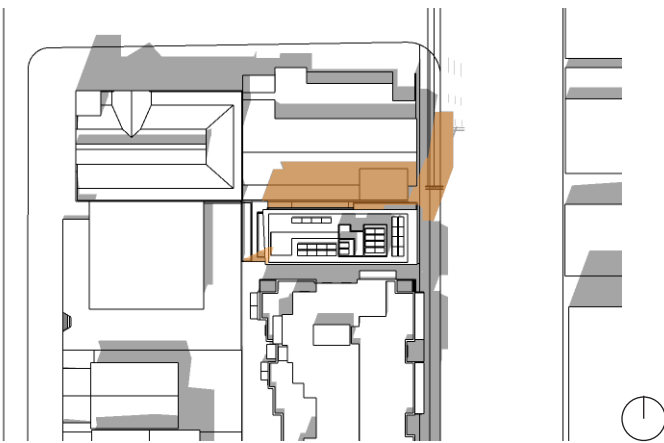

march/september 21
12 pm

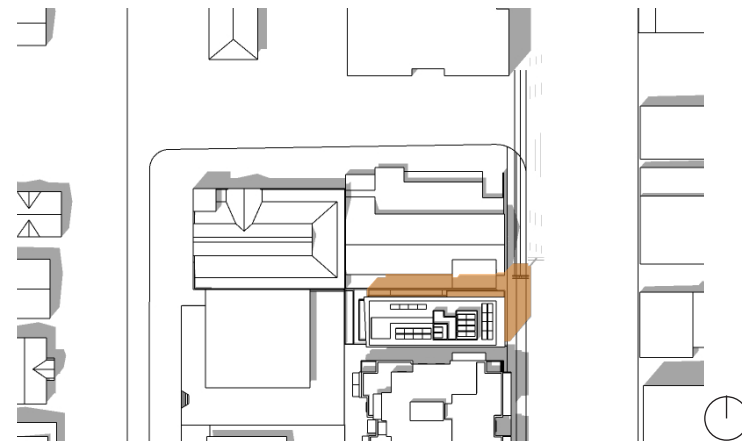

june 21
12 pm

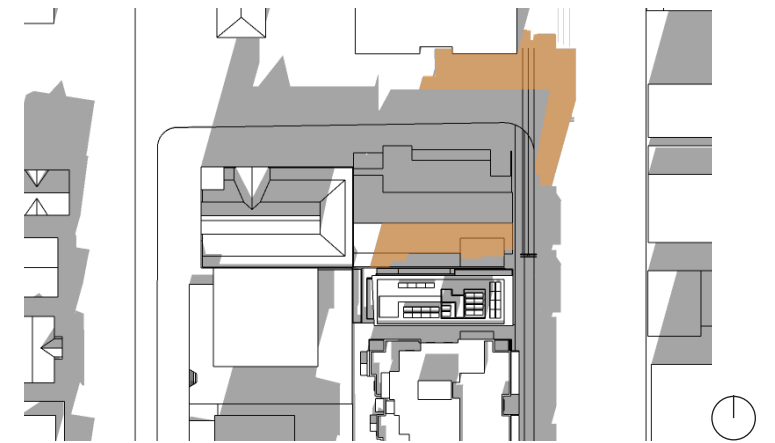

december 21
12 pm

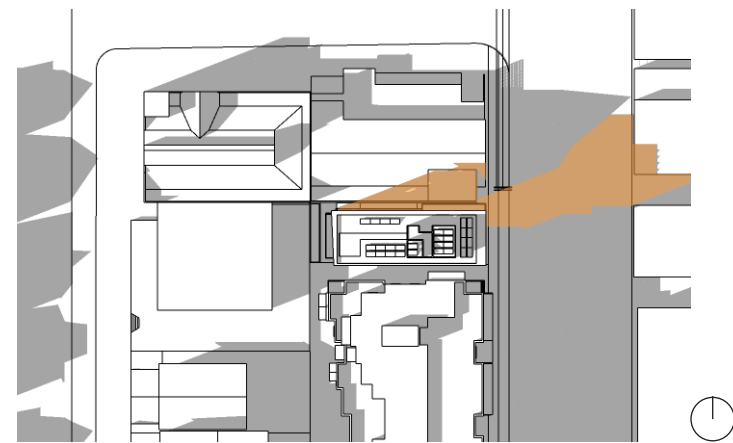

march/september 21
3 pm

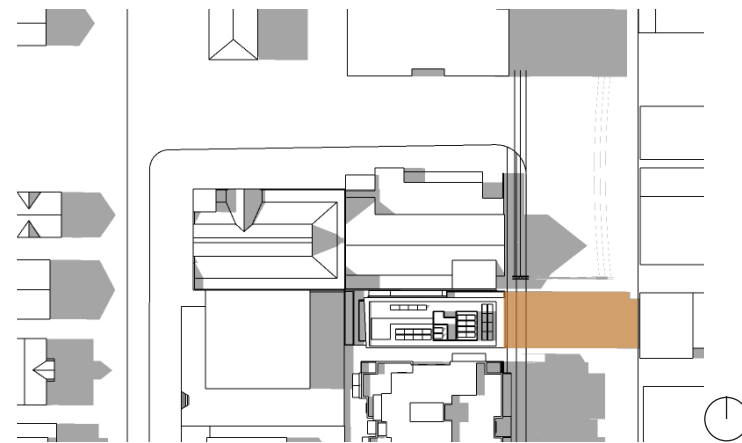

june 21
3 pm

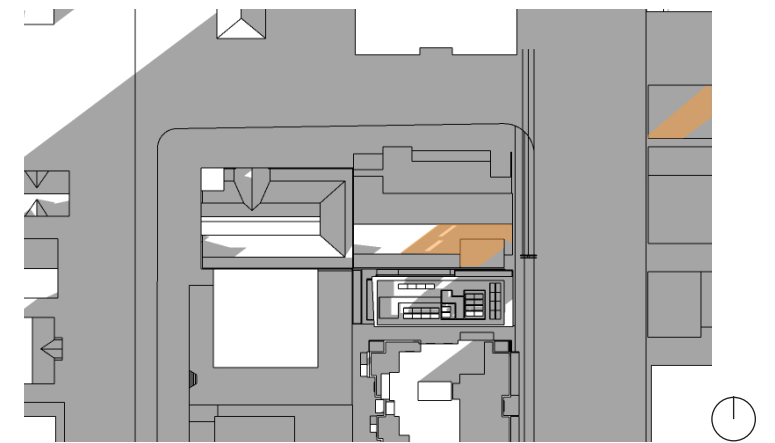

december 21
3 pm

concept C (preferred) // uniform yard

equinox



march/september 21
9 am

summer

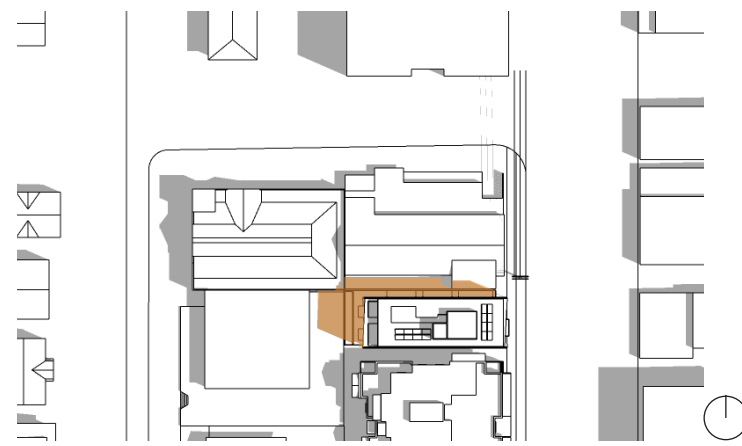

june 21
9 am

winter

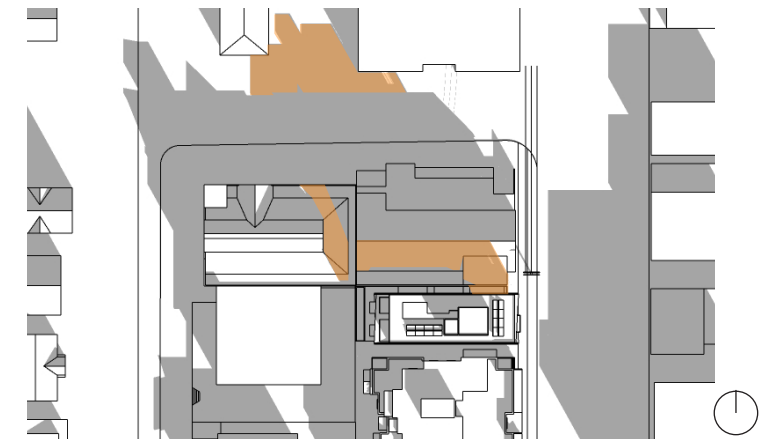

december 21
9 am

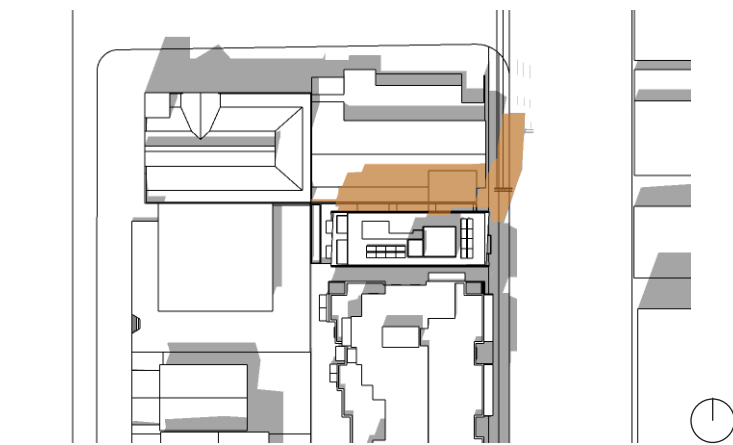

march/september 21
12 pm

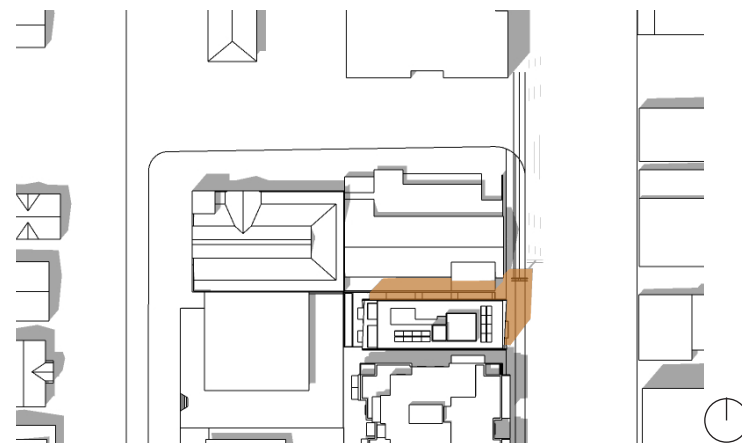

june 21
12 pm

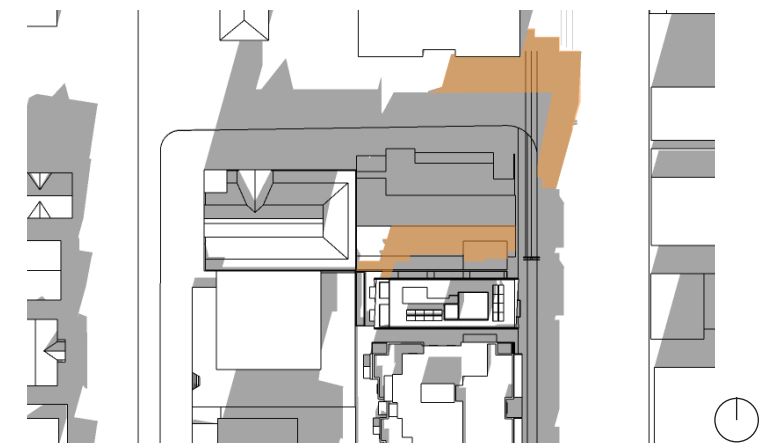

december 21
12 pm

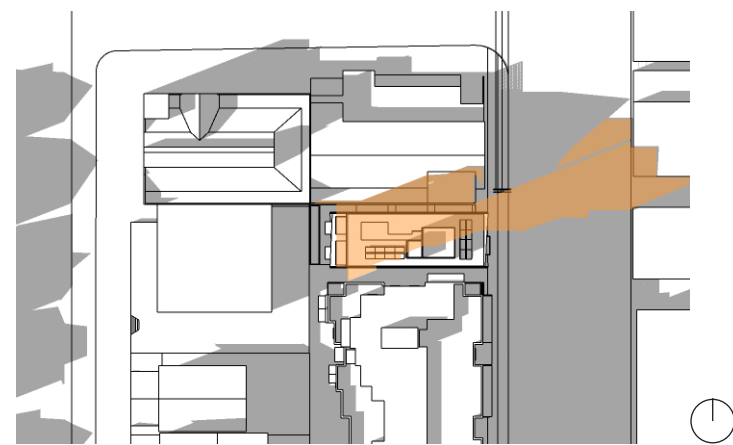

march/september 21
3 pm

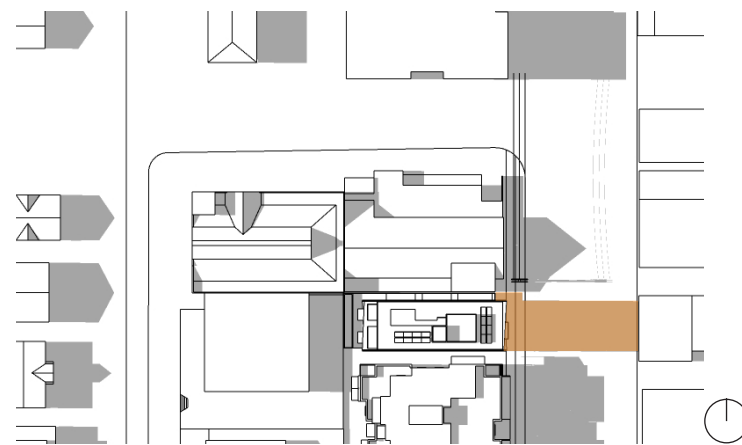

june 21
3 pm

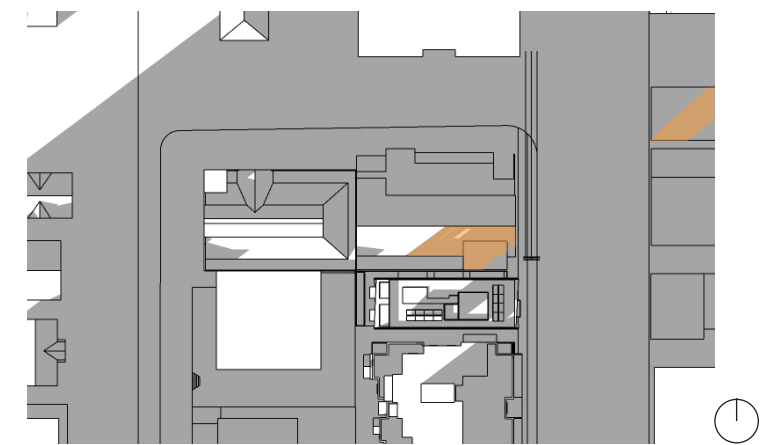

december 21
3 pm

intentionally blank

landscape concept

street plan

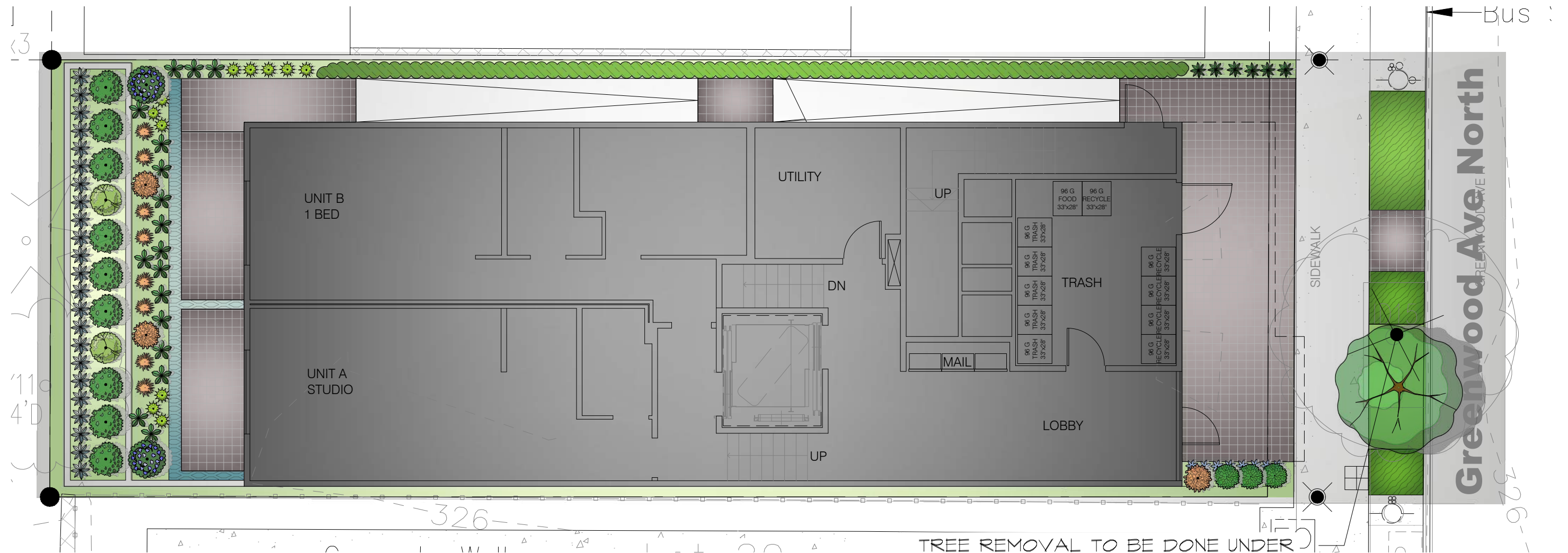

TREE REMOVAL TO BE DONE UNDER SEPARATE SDOT URBAN FORESTRY PERMIT AND WILL REQUIRE 14 DAY NOTIFICATION. EMAIL SDOT UF LANDSCAPE ARCHITECT OFFICE FOR PERMIT ISSUANCE AT DOT_LA@SEATTLE.GOV

RENDERED LANDSCAPE PLAN NTS

NORTH

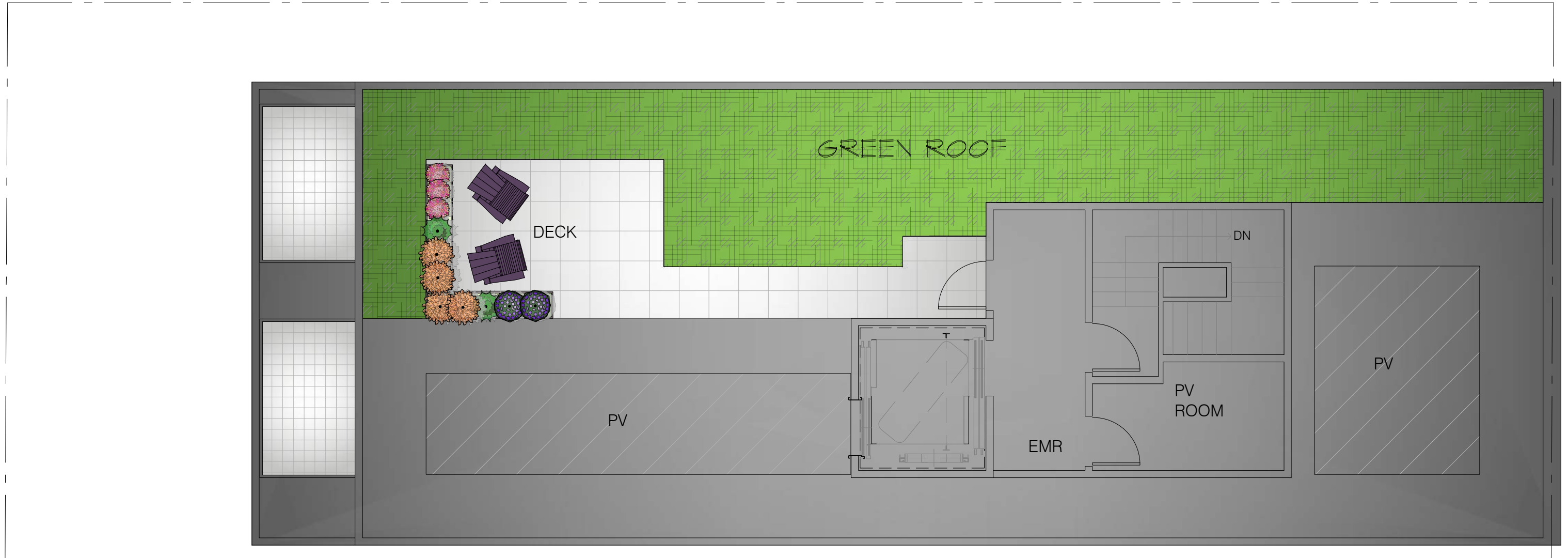

 NORTH RENDERED ROOF PLAN NTS

departures

concept B

departure 1 - west facade

standard

SMC 23.47A.014.B.3 Setbacks

For a structure containing a residential use, a setback is required along any side or rear lot line that abuts a lot in a single-family zone, as follows:

- Fifteen feet for portions of structures above 13 feet in height to a maximum of 40 feet; and
- For each portion of a structure above 40 feet in height, additional setback at the rate of 3 feet of setback for every 10 feet by which the height of such portion exceeds 40 feet

SMC 23.47A.014.G.1a.

Decks with open railings may extend into the required setback, but are not permitted within 5 feet of a lot in a residential zone.

Proposition

In order to provide a more open ground level, provide a consistent architectural expression, modulate the building mass, and create a datum at the fifth floor, we request a departure to provide a 9'-5" setback on the west facade. Note the setback is measured to face of the decks as open railings are not proposed.

Rational

The exterior wall of the building will be located a uniform 15'-5" from the lot line. This creates a significant open space at ground level that will maintain the open feeling between the two lots. It will also allow for landscape elements near the lot line to provide visual screening between the lots and manage the privacy.

Instead of open railings, the balconies that extend from floors two to five include a side wall to the north and south and partially open railings. This partial enclosure will lead the balconies to read as recesses within the body of the structure; enhancing the sense of privacy and creating less visual connections between the dwellings and the neighbors. At the sixth floor the roof is pulled back to the exterior wall to create an expression of a penthouse and a lower perceived height.

Together, the scaling element of the body and the expanded ground level open space better meet the intent of the following design guidelines.

CS2.A.2 architectural presence

CS2.D.3 zoning transitions

CS2.D.5 respect for adjacent sites

DC2.A.2 reducing perceived mass

DC3.B.4 multifamily open space

DC2.C.1 visual depth and interest

DC2.D.2 texture

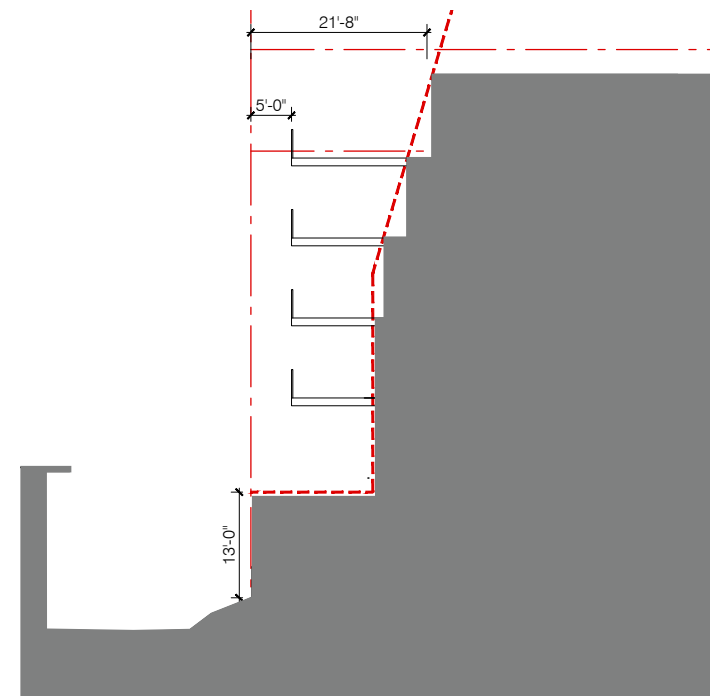

code compliant building section

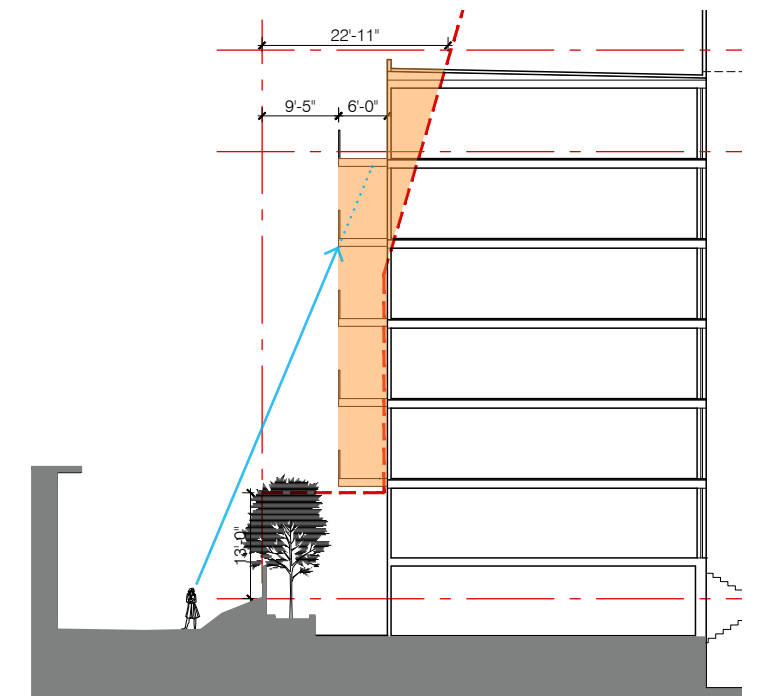

proposed building section

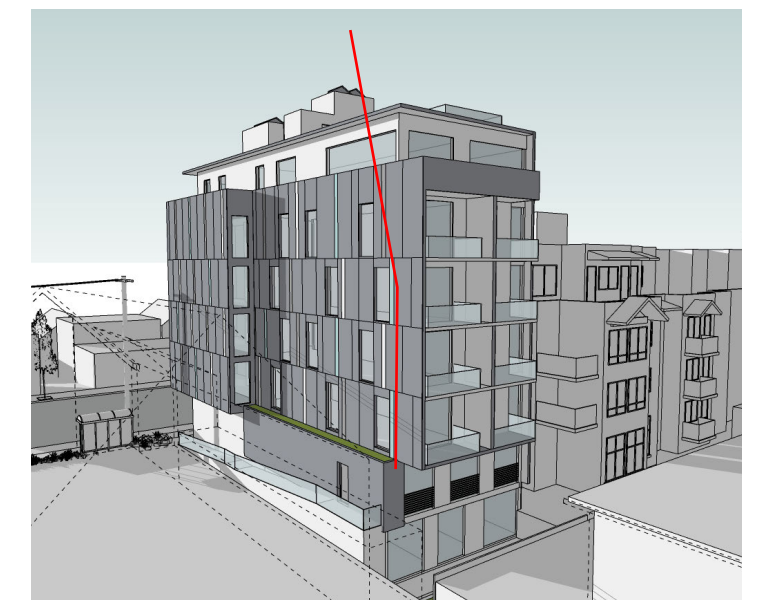

west facade

departure 2 - north facade

standard

SMC 23.47A.014.B.3 Setbacks

For a structure containing a residential use, a setback is required along any side or rear lot line that abuts a lot in a single-family zone, as follows:

- a. Fifteen feet for portions of structures above 13 feet in height to a maximum of 40 feet; and
- b. For each portion of a structure above 40 feet in height, additional setback at the rate of 3 feet of setback for every 10 feet by which the height of such portion exceeds 40 feet

Proposition

In order to provide a cohesive street facing façade, livable dwelling units, and an open space between the project and the Church we request a departure to provide an 11 inch minimum upper-level setback for the first 34.67 feet of the north lot line, increasing to 6.5 feet after that.

Rational

As a small, midblock site, the project is constrained by access needs and an upper-level setback requirement on the west lot line. The site is further constrained by an upper-level setback requirement along the north lot line.

The project site is the only site along the full length of Greenwood Avenue North that is subject to this second upper-level setback—a setback between two lots in the same zone. This is due to the unique situation where the Church property is a lot that spans two zones and the portion zoned SF 5000 is wider than the portion zoned NC2-55(M). It should also be noted that if the Church property were ever to be redeveloped, there would be no required setback on the shared lot line.

To support the City, Woodland Park Presbyterian Church, and the developer’s goals to provide more affordable housing the design team has worked closely with the Church to provide a design that balances daylight to the sanctuary, Church access to their south wall that is located on the lot line, urban presence, building width, and unit function. Through these efforts the project is submitted with Church’s full support.

The proposed design provides a complete urban front, then steps six feet away from the Church to provide open space and daylight to the sanctuary. This set back will provide 15 feet of separation between the translucent clerestory windows and the project. It will also allow for a limited number of windows on the north wall that will activate façade, create visual interest, and scale the façade as a backdrop to the Church. Light colored exterior materials will be used and ledge at the top off the first floor will allow for a narrow set of planters to introduce landscape within the clerestory view. At ground level, the project will set back 3'-11" along the entire lot line.

Together, these elements create a project that better responds to the urban context, provides more housing, preserves ground level access to the Church’s north wall, and preserves daylight to the sanctuary.

CS2.B.1 site characteristics

CS2.C.2 mid-block sites

CS2.D.5 respect for adjacent sites

DC2.D.2 texture

Greenwood/Phinney Supplemental:

CS2-II.i impact of new buildings on the street

CS2.V street pattern

CS2.VII mass and scale

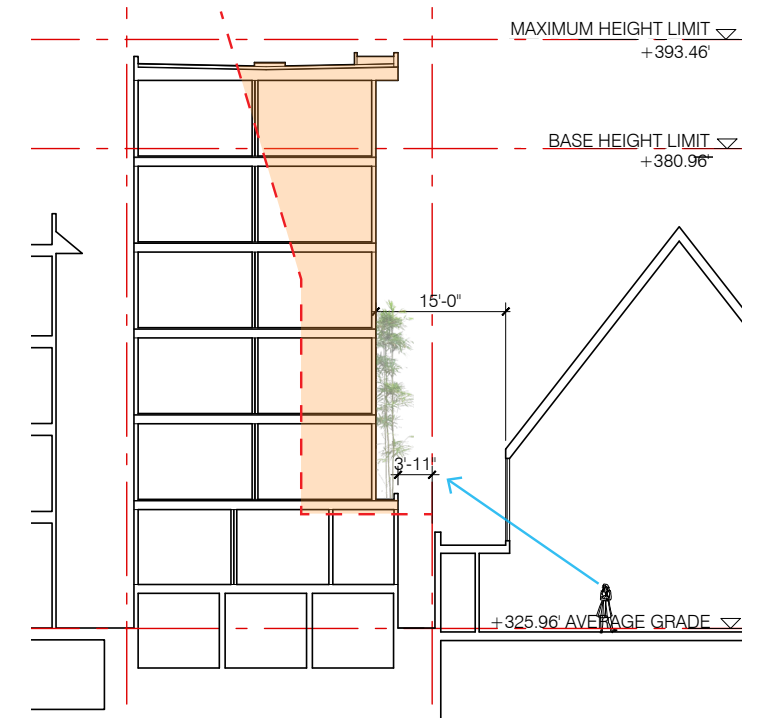
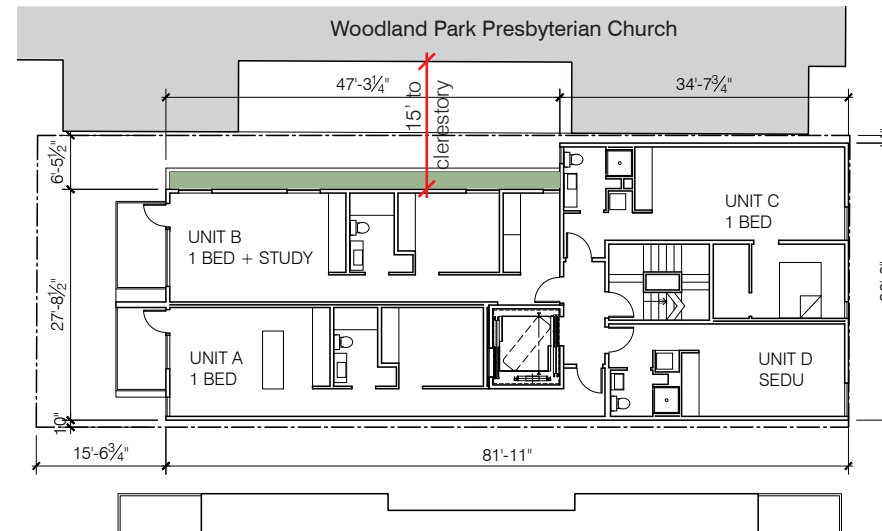

proposed building section



street // southeast view



north facade // birdseye view

concept C

departure 1 - west facade

standard

SMC 23.47A.014.B.3 Setbacks

For a structure containing a residential use, a setback is required along any side or rear lot line that abuts a lot in a single-family zone, as follows:

- a. Fifteen feet for portions of structures above 13 feet in height to a maximum of 40 feet; and
- b. For each portion of a structure above 40 feet in height, additional setback at the rate of 3 feet of setback for every 10 feet by which the height of such portion exceeds 40 feet

SMC 23.47A.014.G.1a.

Decks with open railings may extend into the required setback, but are not permitted within 5 feet of a lot in a residential zone.

Proposition

In order to provide a more open ground level, provide a consistent architectural expression, modulate the building mass, and create a datum at the fifth floor, we request a departure to provide a 15'-5" setback on the west facade. Note the setback is measured to the exterior wall of the building as open railings are proposed.

Rational

The exterior wall of the building will be located 15'-5" from the lot line up to level six, where it will step back to 21'-11". This creates a significant open space at ground level that will maintain the open feeling between the two lots. It will also allow for landscape elements near the lot line to provide visual screening between the lots and manage the privacy.

In keeping with the architectural concept, the façade and perimeter frame provide a consistent expression to the west façade. The setback sixth floor meets the upper-level setback requirement and establishes a datum that reduces the perceived scale of the structure. 6 ft x 6 ft balconies with open railings are secondary elements on the façade that increase privacy from within the dwelling units without adding significant bulk to the façade.

Together, the scaling element of the façade and the expanded ground level open space better meet the intent of the following design guidelines.

CS2.A.2 architectural presence

CS2.D.3 zoning transitions

CS2.D.5 respect for adjacent sites

DC2.A.2 reducing perceived mass

DC3.B.4 multifamily open space

DC2.C.1 visual depth and interest

DC2.D.2 texture

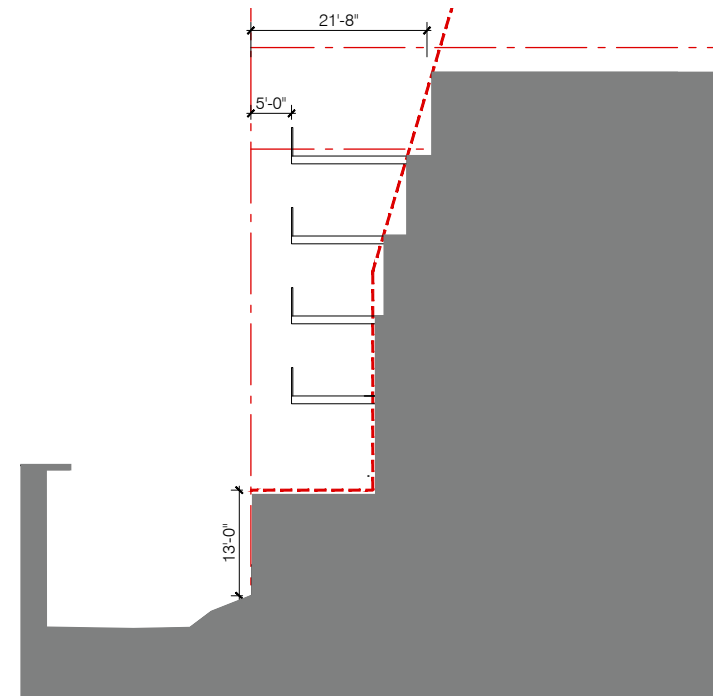

code compliant building section

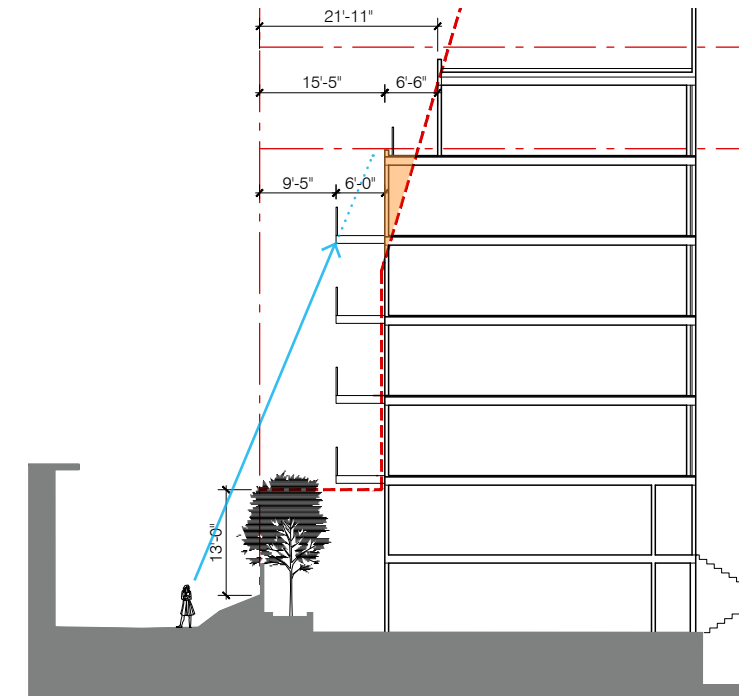

proposed building section

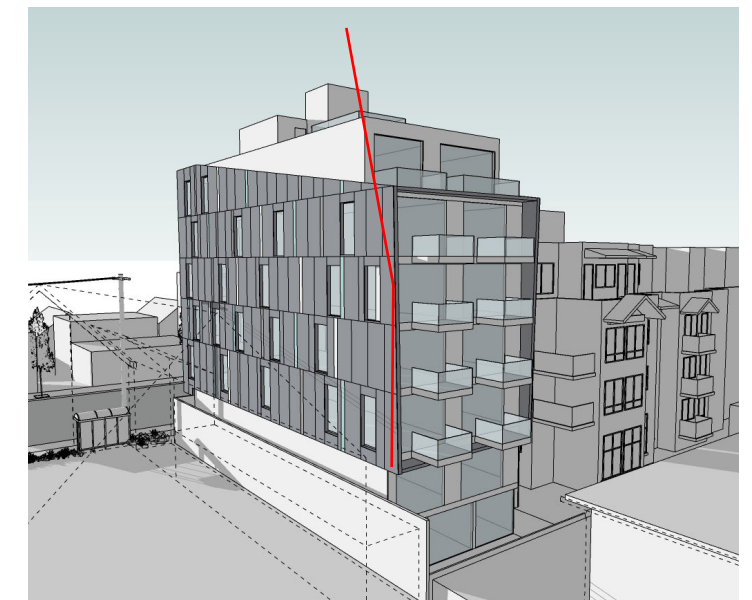

west facade

departure 2 - north facade

standard

SMC 23.47A.014.B.3 Setbacks

For a structure containing a residential use, a setback is required along any side or rear lot line that abuts a lot in a single-family zone, as follows:

- a. Fifteen feet for portions of structures above 13 feet in height to a maximum of 40 feet; and
- b. For each portion of a structure above 40 feet in height, additional setback at the rate of 3 feet of setback for every 10 feet by which the height of such portion exceeds 40 feet

Proposition

In order to provide a cohesive street facing façade, livable dwelling units, and an open space between the project and the Church we request a departure to provide a 5'-0" minimum upper-level setback for the entire north lot line.

Rational

As a small, midblock site, the project is constrained by access needs and an upper-level setback requirement on the west lot line. The site is further constrained by an upper-level setback requirement along the north lot line.

The project site is the only site along the full length of Greenwood Avenue North that is subject to this second upper-level setback—a setback between two lots in the same zone. This is due to the unique situation where the Church property is a lot that spans two zones and the portion zoned SF 5000 is wider than the portion zoned NC2-55(M). It should also be noted that if the Church property were ever to be redeveloped, there would be no required setback on the shared lot line.

To support the City, Woodland Park Presbyterian Church, and the developer's goals to provide more affordable housing the design team has worked closely with the Church to provide a design that balances daylight to the sanctuary, Church access to their south wall that is located on the lot line, urban presence, building width, and unit function. Through these efforts the project is submitted with Church's full support.

The proposed design provides a cohesive urban façade with the entire project set five feet away from the Church to provide open space and daylight to the sanctuary. This set back will provide 13.5 feet of separation between the translucent clerestory windows and the project. It will also allow for a limited number of windows on the north wall that will activate façade, create visual interest, and scale the façade as a backdrop to the Church. Light colored exterior materials will be used.

Together, these elements create a project that better responds to the urban context, provides more housing, preserves Church access to their north wall, and preserves daylight to the sanctuary.

CS2.B.1 site characteristics

CS2.C.2 mid-block sites

CS2.D.5 respect for adjacent sites

DC2.D.2 texture

Greenwood/Phinney Supplemental:

CS2-II.i impact of new buildings on the street

CS2.V street pattern

CS2.VII mass and scale

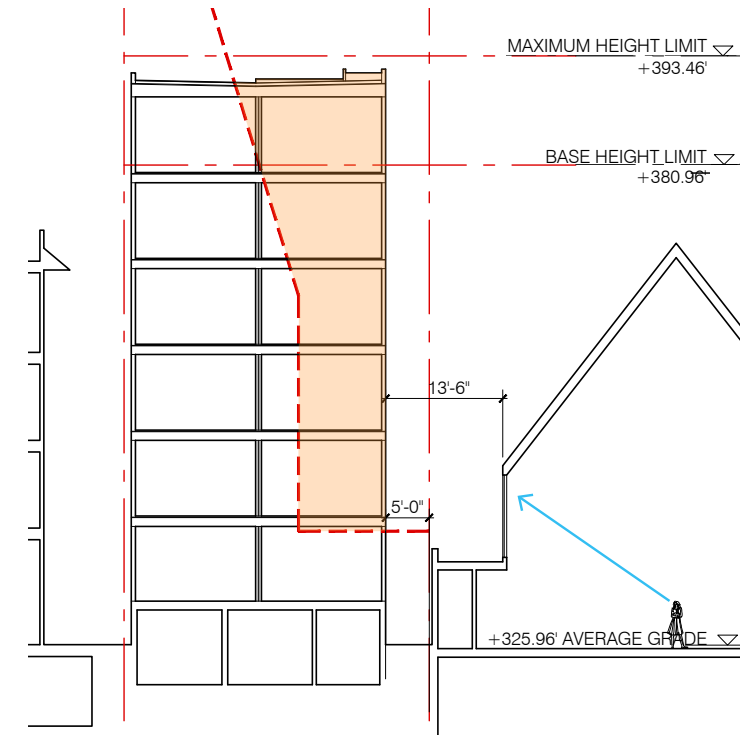
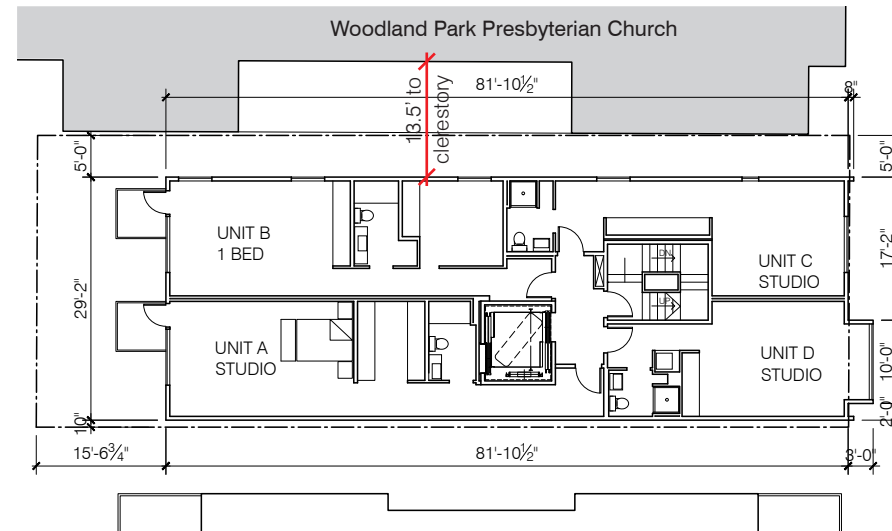

proposed building section



street // southeast view



north facade // birdseye view

departure 3 - blank facade

standard

SMC 23.47A.008.A.2.c Blank facades

The total of all blank facade segments may not exceed 40 percent of the width of the facade of the structure along the street.

Proposition

In order to limit the number of secondary doors on the east façade, we request a departure to allow 56% of the east façade to be blank.

Rational

The narrow, midblock site requires building access, trash room access, and exit stair egress to be provided along or near the front façade of the project. Locating the egress door on the side façade, limits the number of secondary doors on the street façade, but at the same time increases the blank wall percentage for the entire façade to 56%.

The exterior wall and trash room door are proposed as an integrated art or interpretive architectural element that contributes to the cultural memory and public space of the neighborhood. Increasing the length of wall provides more surface area for this work.

CS2.B.2 connection to street

PL1.B.3 pedestrian amenities

PL2.B.3 street-level transparency

DC3.C.3 amenities and features

Greenwood/Phinney Supplemental:

CS2-II.i impact of new buildings on the street

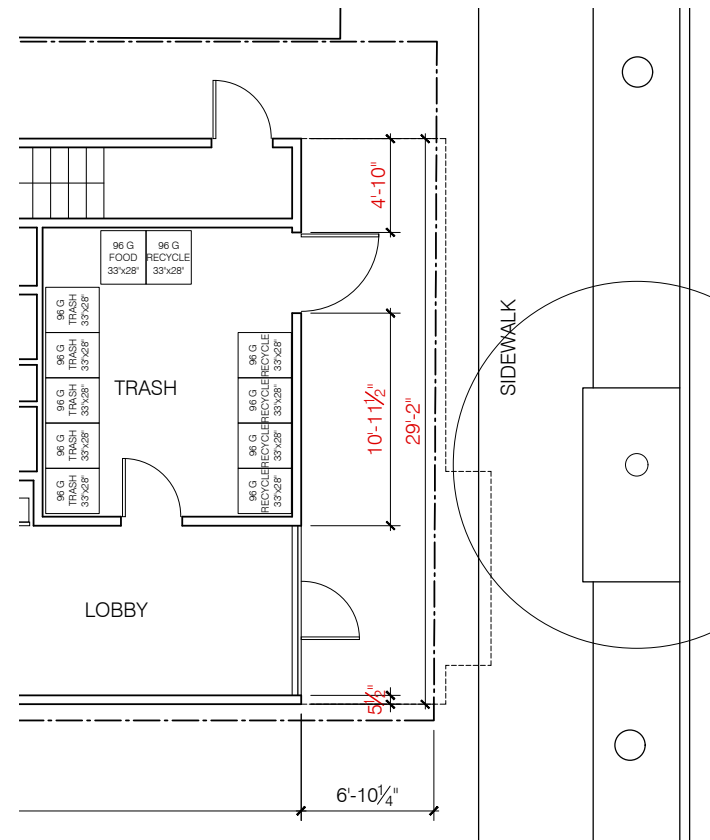

code compliant building section

total blank facade length: $4'-10'' + 10'-11 \frac{1}{2}'' + 5 \frac{1}{2}'' = 16.25'$
 total street-facing facade length: 29.17'

blank facade percentage = 56%

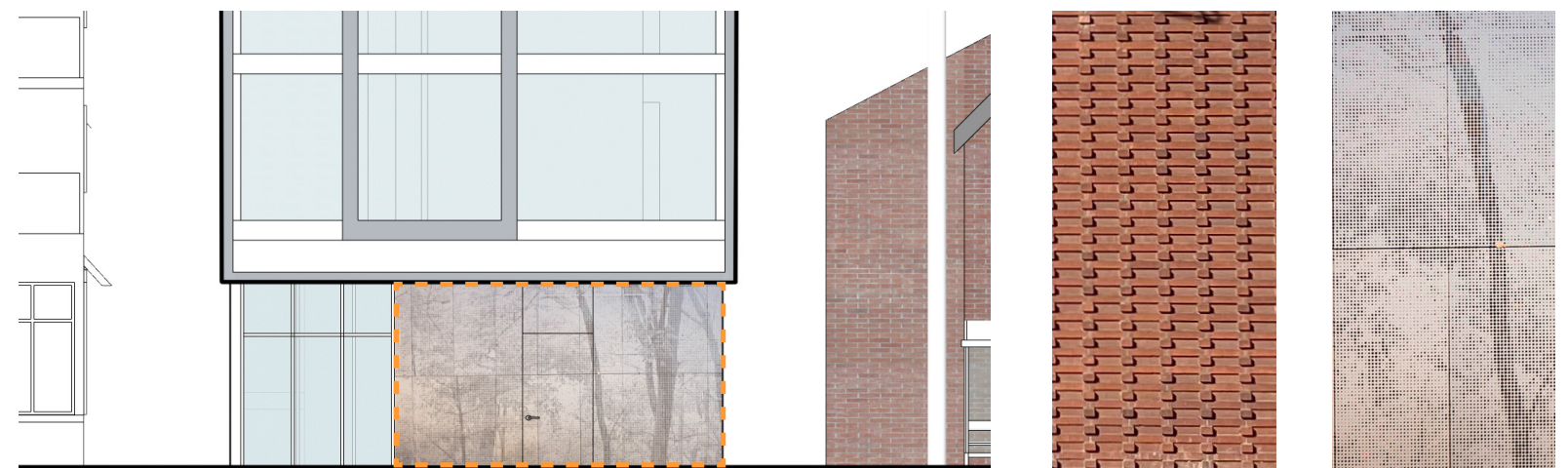

elevation // street level

texture and scale

intentionally blank

architect | developer housing projects



Workshop AD | Stadium 302 condominiums | Tacoma WA



Build Urban | Link Studios | Seattle WA



Workshop AD | Colman triplex | Seattle WA



Workshop AD | Harvard + Denny mix-used | Seattle WA



Living Building Challenge v4.0

6817 Greenwood



Place	LBC Requirement	Approach
I-01	All projects must avoid building on pristine greenfield, wilderness, prime farmland or in a floodplain unless they meet an Exception. Projects must preserve thriving vibrant ecological environments and habitats.	Project is built on previously developed land.
	All project teams must document site and community conditions prior to the start of work, including but not limited to identification fo the project's Reference Habitat.	Reference Habitat: Temperate Conifer Forest & Marine West Coast Forest
	All projects must demonstrate that they contribute positively to the ecology of place and restore or enhance the ecological performance of the site toward a healthy ecological baseline. On-site landscape must be designed to mature and evolve, and to emulate the functionality of the Reference Habitat, as appropriate to the project's Transect.	Living Transect 4 - will ensure landscaping works to emulate the functionality of the Reference Habitat. Landscaping will be incorporated in the residential sunken garden,
	All project teams must assess cultural and social equity factors and needs in the community and consider those identified needs to inform design and process decisions.	Ensure that the community meetings are being documented for this requirement.
	No petrochemical fertilizers or pesticides can be used for the operation and maintenance of the on-site landscape, including urban agriculture.	Will incorporate this requirement into project specifications.
I-04	Increase the density of the site & support a human-powered lifestyle.	Increasing density from a single family house to 18+ unit apartment building. No car parking provided on-site. Enhancing street front pedestrian route with overhang to protect from weather.
	Be built to a human scale that is appropriate for the neighborhood.	The project is located in a lively commercial and residential strip within the Phinney Ridge community which is predominately made up of single-family homes. This strip is composed of grocery stores, five story mixed use developments, walk up apartments, 1-2 story commercial buildings and immediately adjacent to a 3-story townhome complex and a church.
	Provide places for occupants to gather & connect with the community.	Rain Garden
	Provide sufficient secure, weather-protected storage for human-powered vehicles & facilities to encourage biking.	Included.
	Provide at least 2 EV charging stations (or 1 per 30, whichever is greater).	No parking - so no EV required.
	Minimize impervious surface parking.	No parking
	Reduce single-occupancy vehicle trips and trips by fossil fuel-based vehicles by 30% over an established baseline relevant to the project's region & occupancy type OR	
	Implement at least 4 of the following Best Practices: consideration & enhancement of pedestrian routes including weather protection on street frontages, advocacy in the community to facilitate the uptake of human-powered & public transit, transit subsidy for all occupants, carpool coordination assistance, access either to subsidized car sharing and/or to hybrid or EV fleet vehicles, regular survey of occupants to determine current fossil fuel-based SOV trips.	Best Practices: currently enhancing the pedestrian route

Water	LBC Requirement	Approach / Exceptions being applied?
I-05	All projects must not use potable water for irrigation, and use less water for the project's other needs than a baseline regional building of the same type at the following rates: New Building: 50%, Existing Building + Interior: 30%	We should likely meet this by meeting the LBPP's requirement for no potable water for non-potable uses (irrigation & flushing). Plan on treating rainwater & greywater on-site to meet non-potable water demands.
	All projects must treat all stormwater on site through natural or mechanical means and without chemicals and manage all stormwater based on both pre-development hydrology & current ecological conditions.	Will be collecting rainwater to meet our building's non-potable water needs. Will ensure that any stormwater that is not collected will be infiltrated into the ground and does not leave the site.
	All projects on a Combined Sewer Overflow (CSO) system, or in a floodplain must incorporate stormwater dentention & avoid sheet flow off the site.	
Energy	LBC Requirement	Approach / Exceptions being applied?
I-07	Achieve a 70% reduction in total net annual energy consumption (after accounting for on-site renewable power), as compared to a typical existing building with comparable climate, size, use, and occupancy.	LBPP requires our total energy use to be 25% lower than SEC EUI targets. This is a stringent target and will likely get us most (if not all of the way) to the imperative target. Our project is planning to incorporate rooftop PV, efficient heating/cooling/DHW systems, shading & triple pane glazing to reduce our energy consumption.
	Combustion is not allowed (except through existing exceptions) for new construction.	No NG in design. Induction stoves in residential units.
	Meter Energy Used	Metering is required by code. Will add additional meters as required or as beneficial for troubleshooting unexpected energy usage.
	Demonstrate a 20% reduction in the embodied carbon of primary materials (foundation, structure & enclosure) compared to an equivalent baseline.	A building Life Cycle Assessment will be conducted for the primary and interior building materials. The project team will make every attempt to specify materials with lower than average embodied carbon.
	Select interior materials with lower than industry average carbon footprint for product categories for which embodied carbon data is readily available.	
	Be "zero ready" through strategies such as designating area(s) and/or pre-installing wiring & connections for electric vehicle charging & future installation of renewable energy systems.	"Zero Ready" is likely not feasible with our building's small footprint - we will be using the off-site energy exception to produce our remaining required energy.
I-08	Supply 105% of the project's energy needs through on-site renewable energy on a net annual basis, without the use of combustion.	Will be supplied through on and off-site PV arrays.
	Sub-meter major energy end uses.	Metering is required by code. Will add additional meters as required or as beneficial for troubleshooting unexpected energy usage.
	Account for the total embodied carbon emissions (tCO2e) from construction (including the energy consumed during construction) through utilization of carbon-sequestering materials and/or through a one-time carbon offset purchase through an ILFI-approved carbon offset provider.	A building Life Cycle Assessment will be conducted for the primary and interior building materials. The project team will make every attempt to specify materials with lower than average embodied carbon.
Off-site Renewables, High-density / High-EUI Buildings Exception	Develop & incorporate a resilience strategy to allow the building to be habitable for 1 week, or otherwise participate in support for the local community in a disaster, through the use of batteries, storage, etc.	Team will develop an appropriate resilience plan for the building & occupants.
	Projects unable to provide enough renewables on site because they fall under one or more of the project types may locate renewables off site as long as the following requirements are met: renewables are located within the same regional grid, are located consistent with the site criteria of I-01 Ecology of Place, are located on previously developed land or installed in a way to allow continuation of ecologic or natural resource functions, provide additionality, be physically identifiable, be directly metered, be clearly & visibly explained in detail at the LBC project site.	Project must include on-site PV on 75% of the available roof area and designed to provide a minimum TSRF of 75% or greater. The remainder of the required 105% energy will be produced through an off-site array located in the same regional energy grid.

Health + Happiness		LBC Requirement	Approach
I-09	Healthy Interior Environment	Comply with the current version of ASHRAE 62	Project will supply sufficient outdoor air to all residential units
		Prohibit smoking within any buildings or enclosed spaces, and within 25' of any building opening, including air supply vents.	Smoking will be prohibited.
		Develop a Healthy Indoor Environment Plan specific to the project's building type and location. The plan must address cleaning protocols, the prevention of particulates and toxins through an entry approach and implementation of at least one strategy to improve air quality.	The project will develop a HIEP plan to establish cleaning protocols, walk-off mats where appropriate, and IAQ strategies.
		Provide views outside & daylight for 75% of regularly occupied spaces.	Will ensure all units have access to views & daylight as required by this imperative.
		Provide direct exhaust for kitchens, bathrooms, and janitorial areas.	Direct exhaust will be provided for kitchens & bathrooms.
Materials		LBC Requirement	Approach
I-12	Responsible Materials	Project must contain 1 Declare label product per 200 square meters of gross building area, or project area, whichever is smaller, up to 20 distinct products from 5 manufacturers. All other product manufacturers not currently in Declare must, at a minimum, receive a letter requesting they disclose their ingredients & identify any Red List content.	All building materials will be closely selected to comply with responsible materials imperative as well assure we are selecting materials with lower than average embodied carbon.
		Incorporate 1 product certified under the Living Product Challenge	
		50% of wood products must be FSC, salvaged, or harvested on site either for the purpose of clearing the area for construction or to restore or maintain the continued ecological function of the site. The remainder must be from low risk sources.	
		20% or more of the materials construction budget must come from within 500 kilometers of the construction site.	
Divert 80% of the construction waste material from the landfill and provide dedicated infrastructure for the collection of recyclables & compostable food scraps during occupancy.			
Equity		LBC Requirement	Approach
I-17	Universal Access	Make all primary transportation, roads, and non-building infrastructure that are considered externally focused (e.g., plazas, seating, or park space) equally accessible to all members of the public regardless of background, age, and socioeconomic class - including the homeless - with reasonable steps taken to ensure that all people can benefit from the project's creation.	The project will work to provide externally focused infrastructure on the front-facing property.
		Projects in Transect L3-L6 (except single-family residences) must provide for, and enhance the public realm through design measures & features that are accessible to all members of society, such as street furniture, public art, gardens, and benches.	Project will incorporate public art.
		All projects must safeguard access for those with physical disabilities through designs meeting the Principles of Universal design, the Americans with Disabilities Act, and the Architectural Barriers Act Accessibility Guidelines.	Project design will meet ADA guidelines.
		No project may block access to, nor diminish the quality of fresh air, sunlight, and anturial waterways for any member of society or adjacent developments. Projects must also appropriately address any noise audible to the public.	Project design will ensure access to fresh air & sunlight is not diminished.
		Fresh Air: Projects must protect adjacent property from any noxious emissions that would compromise its ability to use natural ventilation. All operational emissions must be free of Red List, persistent bioaccumulative toxicants, and known or suspect carcinogenic, mutagenic, and reprotoxic chemicals.	No parking on project and no noxious emissions.
		Sunlight: Projects must demonstrate that shading of adjacent buildings will not result in significant negative impacts to a majority of the occupants of those buildings.	Our building is located North of the neighboring condo units and set back to ensure that we are not diminishing access to fresh air or sunlight for the neighboring condos.
		Natural Waterways: Projects may not restrict access to the edge of any natural waterway, except where such access can be proven to be a hazard to public safety or would severely compromise the function of the project.	No natural waterways

I-18	Inclusion	Project must have a JUST label for at least 2 project team organizations with an integral role in decisions during both design & construction phases, and an additional 5 organizations involved in the project must complete a JUST Self-Assessment.	Team selected will contain at least 2 JUST project teams.
		Include diverse stateholders from vulnerable or disadvantaged populations in the design, construction, operations & maintenance phases at the following levels: 20% of design contract and/or construction contracts, and 10% of maintenance contracts must be with JUST organizations that meet required levels for Diversity category, or are registered Minority, Women, or Disadvantaged Business Enterprises (MWDBE) organizations. Workforce development/training/community benefits agreements, registered apprentice programs, and similar programs are employed for 10% of the General Contractor's project contracts and/or maintenance contracts.	Team will work to ensure MWDBE organizations & JUST organizations are part of the project team.
		OR Donate 0.1% of the total project cost to a regional, community-based nonprofit organization focused on equity & inclusion.	
Beauty		LBC Requirement	Approach / Exceptions being applied?
I-19	Beauty + Biophilia	Project must be designed to include elements that nurture the innate human/nature connection. Each project team must engage in a minimum of one all-day Biophilic Design Exploration of the biophilic design potential for the project.	The project will integrate public art and contain design features intended solely for human delight and celebration of culture, spirit and the Greenwood neighborhood. Will install interpretative art or other materials to commemorate local history or celebrate local people or events that have made singular contributions to the community.
		Create a Biophilic Framework & Plan for the project that outlines strategy & implementation ideas for the following:	
		How the project will be transformed by deliberately incorporating nature through Environmental Features, Light & Space, and Natural Shapes & Forms.	
		How the project will be transformed by deliberately incorporating nature's patterns through Natural Patterns & Processes and Evolved Human-Nature Relationships.	
How the project will be uniquely connected to the place, climate, and culture through Place-Based Relationships. The project must meaningfully integrate public art and contain design features intended solely for human delight and the celebration of culture, spirit, and place appropriate to the project's function.	Framework should include a record of the Exploration day and goals for the project, as well as historical, cultural, ecological, and climatic studies that thoroughly examine the site and context for the project. The Plan must contain methods for tracking biophilia at each design phase to ensure sufficient implementation for the Framework.		
I-20	Education + Inspiration	Provide a Living Building Challenge Case Study.	Team will work to develop this content and provide an annual open day for the public to at minimum show the non-residential unit portions of the building.
		Provide an annual open day for the public.	
		Provide a copy of the Operations & Maintenance Manual.	
		Provide a simple brochure describing the design & environmental features of the project.	
		Install interpretive signage that teaches visitors & occupants about the project.	
Develop & share an educational website about the project.			
Include one Living Future Accredited Professional on the project team.	Alissa Feucht, the Sustainability Strategist from Glumac is a LFA Professional.		
Seattle LBPP		LBPP Requirement	Approach / Exceptions being applied?
	Energy	Reduce total energy usage by 25% or more based on the EUI targets in the Target Performance Path of the Seattle Energy Code Section C401.3 and use no fossil fuel for space & water heating.	Our project is planning to incorporate rooftop PV, efficient heating/cooling/DHW systems, shading & triple pane glazing to reduce our energy consumption and meet these requirements through efficient design.
	Water	Reduce potable water demand by using only non-potable water to meet the demand for toilet & urinal flushing, irrigation, hose bib, cooling tower (make up water only), and water features, except to the extent other applicable local, state, or federal law requires the use of potable water.	Will be treating greywater/rainwater on-site to meet non-potable water demand.